



FIRE•COMMAND•25/50

Voice Evacuation Control Panel



Installation and Operating Instruction Manual

Installation Precautions - Adherence to the following will aid in problem-free installation with long-term reliability:

WARNING - Several different sources of power can be connected to the fire alarm control panel. Disconnect all sources of power before servicing. Control unit and associated equipment may be damaged by removing and/or inserting cards, modules, or interconnecting cables while the unit is energized. Do not attempt to install, service, or operate this unit until this manual is read and understood.

CAUTION - *System Reacceptance Test after Software Changes:* To ensure proper system operation, this product must be tested in accordance with NFPA 72-1993 Chapter 7 after any programming operation or change in site-specific software. Reacceptance testing is required after any change, addition or deletion of system components, or after any modification, repair or adjustment to system hardware or wiring.

All components, circuits, system operations, or software functions known to be affected by a change must be 100% tested. In addition, to ensure that other operations are not inadvertently affected, at least 10% of initiating devices that are not directly affected by the change, up to a maximum of 50 devices, must also be tested and proper system operation verified.

This system meets NFPA requirements for operation at 0-49° C/32-120° F and at a relative humidity of 85% RH (non-condensing) at 30° C/86° F. However, the useful life of the system's standby batteries and the electronic components may be adversely affected by extreme temperature ranges and humidity. Therefore, it is recommended that this system and its peripherals be installed in an environment with a nominal room temperature of 15-27° C/60-80° F.

Verify that wire sizes are adequate for all initiating and indicating device loops. Most devices cannot tolerate more than a 10% I.R. drop from the specified device voltage.

Like all solid state electronic devices, this system may operate erratically or can be damaged when subjected to lightning induced transients. Although no system is completely immune from lightning transients and interferences, proper grounding will reduce susceptibility. Overhead or outside aerial wiring is not recommended, due to an increased susceptibility to nearby lightning strikes. Consult with the Technical Services Department if any problems are anticipated or encountered.

Disconnect AC power and batteries prior to removing or inserting circuit boards. Failure to do so can damage circuits.

Remove all electronic assemblies prior to any drilling, filing, reaming, or punching of the enclosure. When possible, make all cable entries from the sides or rear. Before making modifications, verify that they will not interfere with battery, transformer, and printed circuit board location.

Do not tighten screw terminals more than 9 in-lbs. Over tightening may damage threads, resulting in reduced terminal contact pressure and difficulty with screw terminal removal.

This system contains static-sensitive components. Always ground yourself with a proper wrist strap before handling any circuits so that static charges are removed from the body. Use static suppressive packaging to protect electronic assemblies removed from the unit.

Follow the instructions in the installation, operating, and programming manuals. These instructions must be followed to avoid damage to the control panel and associated equipment. FACP operation and reliability depend upon proper installation.

Fire Alarm System Limitations

While installing a fire alarm system may make lower insurance rates possible, it is not a substitute for fire insurance!

An automatic fire alarm system - typically made up of smoke detectors, heat detectors, manual pull stations, audible warning devices, and a fire alarm control with remote notification capability can provide early warning of a developing fire. Such a system, however, does not assure protection against property damage or loss of life resulting from a fire.

Any fire alarm system may fail for a variety of reasons:

Smoke detectors may not sense fire where smoke cannot reach the detectors such as in chimneys, in walls, or roofs, or on the other side of closed doors. Smoke detectors also may not sense a fire on another level or floor of a building. A second floor detector, for example, may not sense a first floor or basement fire. Furthermore, all types of smoke detectors - both ionization and photoelectric types, have sensing limitations. No type of smoke detector can sense every kind of fire caused by carelessness and safety hazards like smoking in bed, violent explosions, escaping gas, improper storage of flammable materials, overloaded electrical circuits, children playing with matches, or arson.

IMPORTANT! *Smoke detectors must be installed in the same room as the control panel and in rooms used by the system for the connection of alarm transmission wiring, communications, signaling, and/or power.* If detectors are not so located, a developing fire may damage the alarm system, crippling its ability to report a fire.

Audible warning devices such as bells may not alert people if these devices are located on the other side of closed or partly open doors or are located on another floor of a building.

A fire alarm system will not operate without any electrical power. If AC power fails, the system will operate from standby batteries only for a specified time.

Rate-of-Rise heat detectors may be subject to reduced sensitivity over time. For this reason, the rate-of-rise feature of each detector should be tested at least once per year by a qualified fire protection specialist.

Equipment used in the system may not be technically compatible with the control. It is essential to use only equipment listed for service with your control panel.

Telephone lines needed to transmit alarm signals from a premise to a central monitoring station may be out of service or temporarily disabled.

The most common cause of fire alarm malfunctions, however, is inadequate maintenance. All devices and system wiring should be tested and maintained by professional fire alarm installers following written procedures supplied with each device. System inspection and testing should be scheduled monthly or as required by National and/or local fire codes. Adequate written records of all inspections should be kept.

FCC Warning

WARNING: This equipment generates, uses, and can radiate radio frequency energy and if not installed and used in accordance with the instruction manual, may cause interference to radio communications. It has been tested and found to comply with the limits for class A computing device pursuant to Subpart B of Part 15 of FCC Rules, which is designed to provide reasonable protection against such interference when operated in a commercial environment. Operation of this equipment in a residential area is likely to cause interference, in which case the user will be required to correct the interference at his own expense.

Canadian Requirements

This digital apparatus does not exceed the Class A limits for radiation noise emissions from digital apparatus set out in the Radio Interference Regulations of the Canadian Department of Communications.

Le présent appareil numérique n'émet pas de bruits radioélectriques dépassant les limites applicables aux appareils numériques de la classe A prescrites dans le Règlement sur le brouillage radioélectrique édicté par le ministère des Communications du Canada.

Table of Contents

CHAPTER 1: Product Description	6
1.1: Product Features	6
FIGURE 1-1: Command Board with Supplied Power Supply Module	8
FIGURE 1-2: Command Board With Amplifiers	9
1.2: Specifications	10
1.3: Controls and Indicators	11
FIGURE 1-3: Controls and Indicators	11
1.4: Circuits	12
1.5: Components	13
FIGURE 1-4: Main Circuit Board	13
FIGURE 1-5: Cabinet	13
FIGURE 1-6: Dress Panel	13
1.6: Optional Modules	13
CHAPTER 2: Field Programming.....	15
FIGURE 2-1: Field Programming DIP Switches.....	15
2.1: S1 DIP Switch Settings	15
TABLE 2-1: Switch Settings for Tones.....	15
2.2: S5 DIP Switch Settings	16
TABLE 2-2: Switch Settings for Message Repeat.....	16
TABLE 2-3: One 60 Second Message - Amp Selected.....	17
TABLE 2-4: Two 30 Second Messages - Message Selected.....	17
2.3: S2 - Record Bypass Switch	18
CHAPTER 3: Installation	19
3.1: Mounting Options	19
FIGURE 3-1: VECP Cabinet	19
3.2: Backbox Installation.....	19
FIGURE 3-2: FC-TR Trim Ring.....	19
FIGURE 3-3: Cabinet Dimensions & Knockout Locations.....	20
FIGURE 3-4: VECP Backbox and Battery Box	21
3.3: Operating Power	22
FIGURE 3-5: Operating Power Connections.....	22
3.4: Auxiliary DC Power Output Connections.....	23
FIGURE 3-6: Auxiliary Power Connection.....	23
3.5: Input Circuits.....	23
FIGURE 3-7: Command Input Circuits	23
3.6: Output Circuits	24
FIGURE 3-8: Example 1 - Activating Multiple VECPs with Master CMD Output Bus	24
FIGURE 3-9: Example 2 - Activating MR-101C (or MR-201C) with Master CMD Output Bus	24
FIGURE 3-10: Trouble Relay	25
FIGURE 3-11: AC Power Loss Relay	25
FIGURE 3-12: Speaker Circuit Connections.....	25
3.7: UL Power-limited Wiring Requirements	26
FIGURE 3-13: Typical Wiring Diagram for UL Power-limited Requirements	26
3.8: Installation of Option Modules	27
3.8.1: Audio Amplifier Module (FC-AAM25)	27
FIGURE 3-14: Installation of Optional Audio Amplifier.....	27
3.8.2: 70.7 V _{RMS} Transformer Module (FC-XRM70)	28
FIGURE 3-15: 70.7 V _{RMS} Transformer Module Installation	28
3.8.3: Power Supply/Battery Charger Module FC-PSM(E).....	29
FIGURE 3-16: Installation of FC-PSM(E) Power Supply/Battery Charger Module	29
3.8.4: Transformer Installation.....	30

FIGURE 3-17: Installation of Power Supply Transformer	30
3.8.5: Local Playback Speaker Module (FC-LPS)	31
FIGURE 3-18: Installation of Speaker Module	31
CHAPTER 4: Operating Instructions	32
4.1: Switches.....	32
4.1.1: Manual Evacuate/Message Override	32
FIGURE 4-1: Front Panel	32
4.1.2: REC - Record Push Button.....	32
4.1.3: Playback Button	34
4.2: LED Indicators	35
4.2.1: LEDs Visible with Backbox Door Closed (Refer to Figure 4-1 on page 32).....	35
4.2.2: LEDs Visible with Door Open and Optional Dress Panel Removed (Figure 1-1 & Figure 1-2)	35
4.3: Operation	35
4.3.1: Fire Alarm	36
4.3.2: Fire Alarm Restoral	36
4.3.3: Manual Evacuation Switch Activation	36
4.3.4: Manual Evacuation Switch Restoral	36
4.3.5: Message Override Switch.....	37
4.3.6: Trouble Condition Response	37
4.3.7: Trouble Condition Restoral	38
CHAPTER 5: Application Examples	40
5.1: One Speaker Circuit	40
FIGURE 5-1: One 25 Watt Speaker Circuit	40
5.2: One Speaker Circuit With Backup	41
FIGURE 5-2: One 25 Watt Speaker Circuit With Backup	41
5.3: Two Speaker Circuits - One 60 Second Message On Both Amps.....	42
FIGURE 5-3: Two Speaker Circuits - One 60 Second Message On Both Amps	42
5.4: Two Speaker Circuits - Two 30 Sec. Messages (Fire and Nonfire).....	43
FIGURE 5-4: Two Speaker Circuits - Two Messages	43
5.5: Two Speaker Circuits - One or Two Messages (CMD1 and CMD2 Amp Selection)	44
FIGURE 5-5: Two Speaker Circuits - One of Two Messages	44
Appendix A: Battery Calculations	45
TABLE A-1: Battery Calculations	45
TABLE A-2: Regulated Load in Standby	45
TABLE A-3: Regulated Load in Alarm	46
Appendix B: Digital Voice Messages	47
Appendix C: FCPS-24F(E) Connections	48
FIGURE C-1: FCPS-24F(E) Connections to FIRE•COMMAND•25/50	48
Appendix D: Addressable Module Connections	49
FIGURE D-1: Addressable Module Connections	49
Appendix E: Wiring Requirements	50
TABLE E-1: FIRE•COMMAND•25/50 Wiring Requirements	50

This control panel has been designed to comply with standards set forth by the following regulatory agencies:

- Underwriters Laboratories Standard UL 864
- NFPA 72 National Fire Alarm Code
- CAN/ULC - S527-M87 Standard for Control Units for Fire Alarm Systems

Before proceeding, the installer should be familiar with the following documents.



NFPA Standards

This Fire Alarm Control Panel complies with the following NFPA Standards:

NFPA 72 National Fire Alarm Code

Note: Audible signal appliances used in public mode applications, are required to have minimum sound levels of 75 dBA at 10 feet (3 meters) and a maximum level of 120 dBA at the minimum hearing distance from the audible appliance.

To ensure that the appliance is clearly heard, the audible appliance sound level must be at least 15 dBA above the average ambient sound level or 5 dBA above the maximum sound level with a duration of at least 60 seconds, depending on which level is greater, with the sound level being measured 5 feet (1.5 meters) above the floor.



Underwriters Laboratories Documents:

UL 38 Manually Actuated Signaling Boxes

UL 217 Smoke Detectors, Single and Multiple Station

UL 228 Door Closers–Holders for Fire Protective Signaling Systems

UL 268 Smoke Detectors for Fire Protective Signaling Systems

UL 268A Smoke Detectors for Duct Applications

UL 346 Waterflow Indicators for Fire Protective Signaling Systems

UL 464 Audible Signaling Appliances

UL 521 Heat Detectors for Fire Protective Signaling Systems

UL 864 Standard for Control Units for Fire Protective Signaling Systems

UL 1481 Power Supplies for Fire Protective Signaling Systems

UL 1638 Visual Signaling Appliances

UL 1711 Amplifiers for Fire Protective Signaling Systems

UL 1971 Signaling Devices for Hearing Impaired

CAN/ULC - S524-M91 Standard for Installation of Fire Alarm Systems



Other:

NEC Article 250 Grounding

NEC Article 300 Wiring Methods

NEC Article 760 Fire Protective Signaling Systems

Applicable Local and State Building Codes

Requirements of the Local Authority Having Jurisdiction (LAHJ)

Fire•Lite Documents

Fire•Lite Device Compatibility Document Document #15384

FCPS-24F(E) Field Charger/Power Supply Document #50079

MS-9200 Technical Manual Document #15668

MS-9200E Export Technical Manual Document #50428

CHAPTER 1 *Product Description*

The FIRE•COMMAND•25/50 Voice Evacuation Control Panel (VECP) is a single-channel, 25 watt, 25 V_{RMS}, emergency voice evacuation panel. The panel includes dual field programmable message capability (up to 60 seconds) and an integral microphone. The base configuration requires that 24 VDC regulated power be provided to the FIRE•COMMAND•25/50 for operational power. A separate custom power supply module with battery charger is available and may be installed as an option to provide the 24 VDC regulated power. An optional second 25 watt amplifier is also available for backup purposes or to provide an additional channel of 25 watts. Optional 70 V_{RMS} conversion modules are also available for installations where 70 V_{RMS} speakers are to be installed or already exist. The modular design allows for ease-of-serviceability.

Two Command Input Circuits can be independently field programmed for activation by an FACP Notification Appliance Circuit reverse polarity or by closure of a supervised normally open contact. Terminals are provided for NAC input and output to allow installation of the FIRE•COMMAND•25/50 anywhere along the NAC circuit being used to activate it. Options via the Command Inputs allow one 60 second message over both amplifiers simultaneously or by selecting amplifiers individually, two 30 second messages may be selected.

Significant technological enhancements set the FIRE•COMMAND•25/50 apart from other voice panels. These enhancements include full supervision in both active (alarm or music) and standby conditions. Supervision is provided for:

- ✓ amplifier outputs
- ✓ field wiring (shorts and opens)
- ✓ message generator
- ✓ all tone generators
- ✓ microphone

If the message generator fails, the system automatically reverts to the primary tone generator. If the primary tone generator fails, one of three backups become enabled.

Power is fed independently to each amplifier so that a short circuit in one amplifier will not shut down the other. Full output power of 25 watts per amplifier is generated while in a low battery condition. Power is not diminished when the 70 V_{RMS} option is installed. Audio is amplified from modern integrated circuits as opposed to transformer technology. This provides for very low signal distortion for crystal clear audio.

Primary applications for the FIRE•COMMAND•25/50 include nonhigh-rise structures such as restaurants, schools, auditoriums, places of worship, buildings with occupancies over 50, etc. The FIRE•COMMAND•25/50 is designed to interface directly to addressable or conventional fire alarm control panels or act as a complete stand-alone unit.

1.1 Product Features

- 25 watts (25 V_{RMS}) audio power (expandable to 50 watts)
- Modular design for maximum system flexibility
- Unobstructed module access and removable terminal blocks for ease of servicing and module replacement
- Designed to allow easy system expansion
- Dual Command Input circuits field selectable to be activated from 12 or 24 VDC Notification Appliance Circuits (reverse polarity) or contact closures
- Single Style Y or Z speaker circuit (expandable to two with optional 25 watt expander amplifier)
- Integral supervised microphone

Product Features

- Integral digital message repeater with 'primary' and 'secondary' dual-message capability
- Standard, prerecorded message:
 - “May I have your attention please. May I have your attention please. The signal you have just heard indicates a report of a fire in this building. Please proceed to the nearest exit and leave the building. Do not reenter the building unless directed to do so by the proper authorities.”
- Field-selectable message capability and custom message field recording capability using local microphone or compatible audio input jack
- Two 30 second or one 60 second custom message
- Integral tone generators field selectable for steady, slow-whoop, high-low or chime tones
- Multiple Master configurations allow higher wattage capability
- Powered by:
 - ✓ optional internal power supply and battery charger (up to 17 AH) module FC-PSM(E)
 - ✓ host FACP
 - ✓ external UL listed power supply such as the Fire•Lite FCPS-24F(E)
- Optional 70.7 V_{RMS} conversion module available for each amplifier
- Piezo sounder for local trouble
- Independent Form-C trouble relay
- 35 mA auxiliary power output for addressable control modules (when interfaced with the Fire•Lite MS-9200(E) FACP or equivalent) and End-of-Line power supervision relays
- Integral Dress Panel
- Optional local playback speaker and record control functions
- Auxiliary Audio Input for recording custom message from compatible source or playing music over the system with prior approval of Local Authority Having Jurisdiction (LAHJ)
- Manual Evacuate/Message Override two position switch for transmission of stored voice messages or microphone interrupt
- System LEDs (visible with cabinet door closed):
 - ✓ Power ON (green)
 - ✓ System Trouble (yellow)
 - ✓ Alarm (red)
 - ✓ Microphone Trouble (yellow)
 - ✓ Tone Generator Trouble (yellow)
 - ✓ Message Generator Trouble (yellow)
 - ✓ Record (green)
- Other System LEDs (located on modules)
 - ✓ Ground Fault (yellow) - optional FC-PSM(E) Power Supply Module
 - ✓ Battery Trouble (yellow) - optional FC-PSM(E) Power Supply Module
 - ✓ AC On (green) - optional FC-PSM(E) Power Supply Module
 - ✓ Amplifier Supervision (green) - Amplifier Module
 - ✓ Wiring Fault/Amplifier Fail (yellow) - Amplifier Module

FIGURE 1-1: Command Board with Supplied Power Supply Module

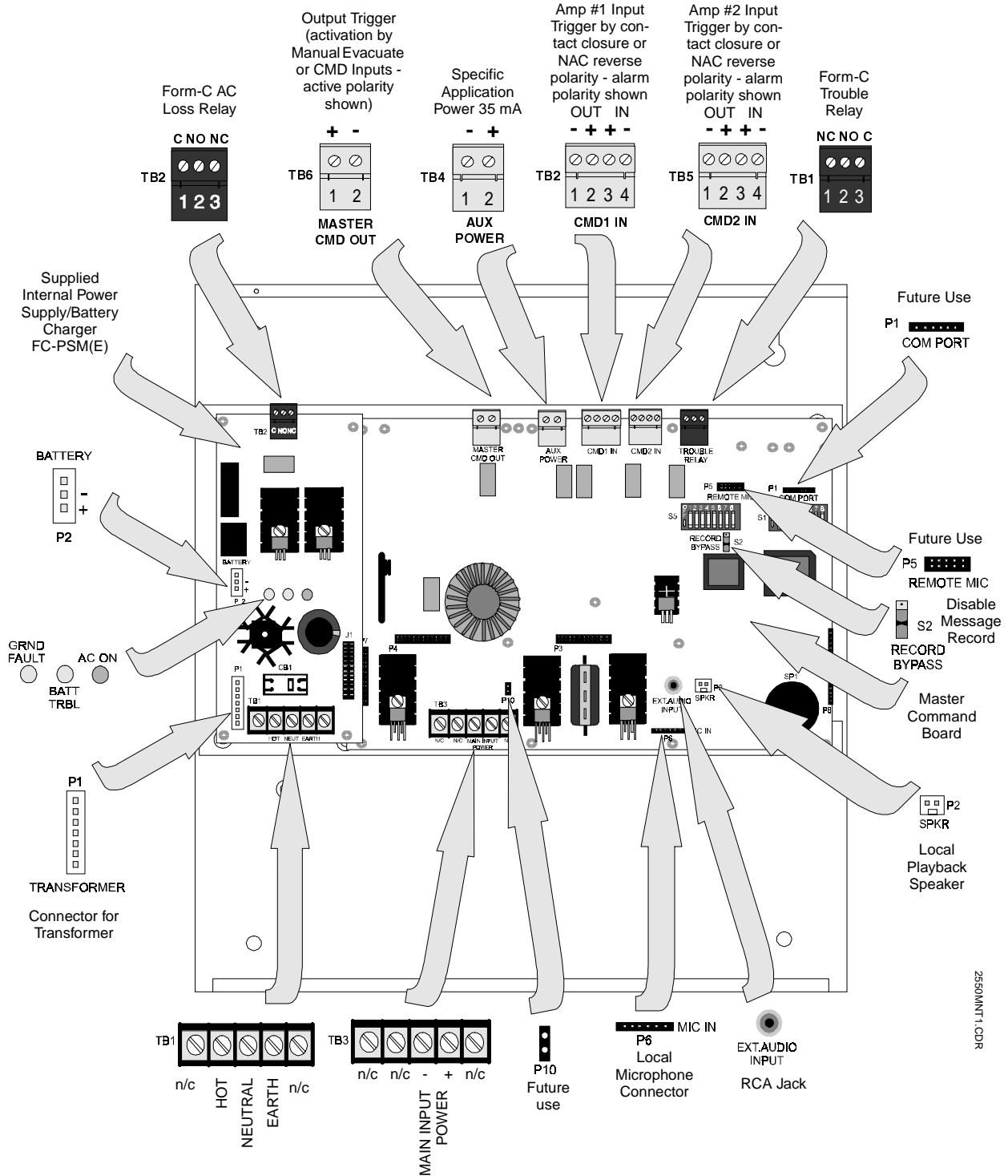

2550NMNT1.CDR

FIGURE 1-2: Command Board With Amplifiers

CAUTION: Match proper polarity connections to field wiring and speakers. Polarity shown is in the standby and alarm conditions.

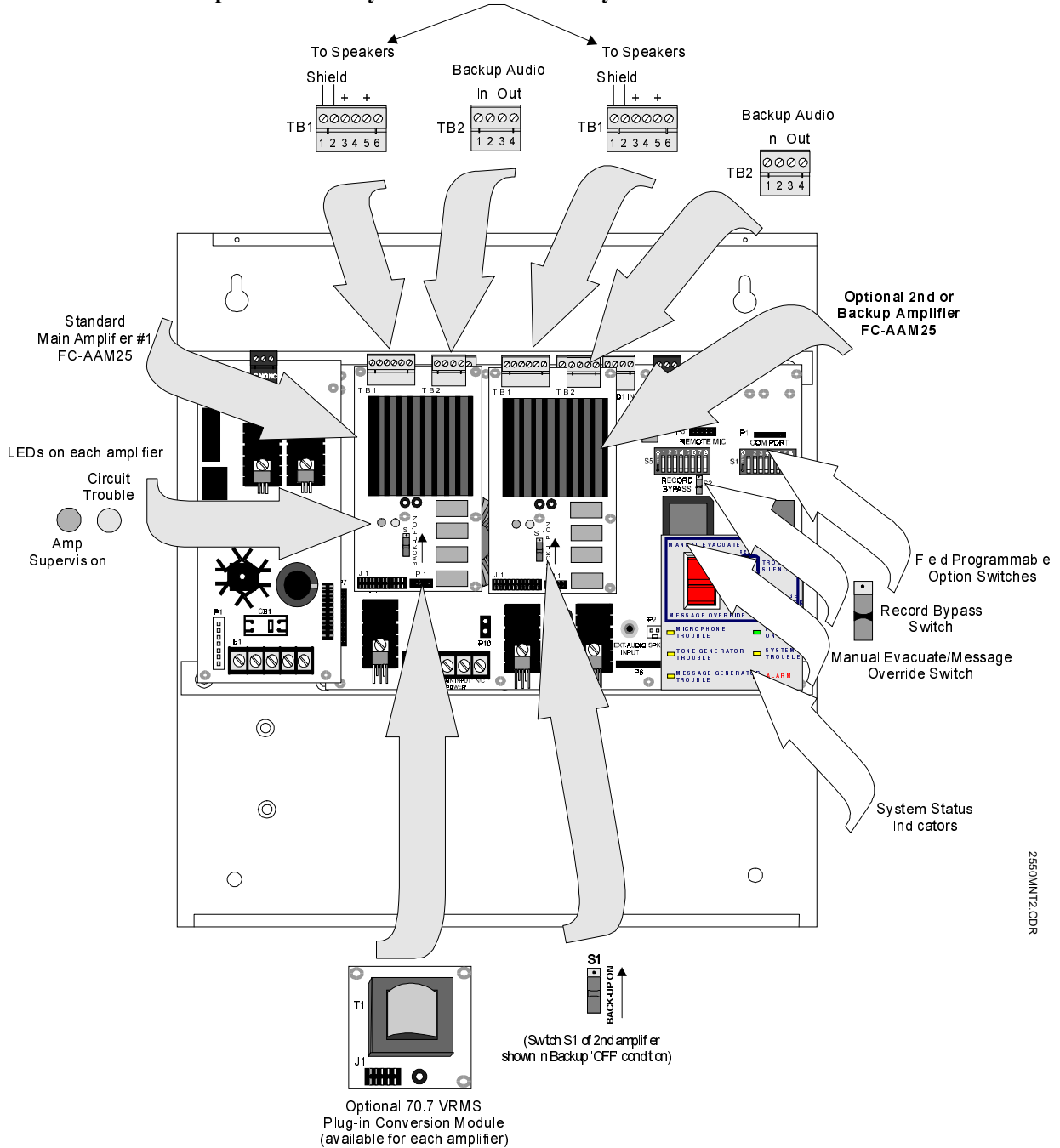

25500/NT2.CDR

1.2 Specifications

Main Input Power - TB3 Terminals 3(-) and 4(+)

Filtered 19.1 - 26.4 VDC, 4.2 amps maximum, supplied by an FACP or remote power supply UL listed for Fire Protective Signaling Service, such as the FCPS-24F(E). See Appendices for compatibility chart and wiring diagrams. Use battery calculation tables in Appendix A to determine the actual current requirements. *Note: When using power from the host FACP or a remote power supply, the FIRE•COMMAND•25/50 power requirements must be included in the FACP or remote power supply battery calculations.*



CAUTION: When optional FC-PSM(E) Power Supply/Battery Charger Module is installed, do not connect external power to Terminals 3 and 4. Terminals must have no wiring connected to them.

TB3 Terminals 1(-) and 2(+)

Future Use - Do not connect to field wiring.

Optional Internal Power Supply/Battery Charger FC-PSM(E) - Plugs into P7 of the main circuit board

AC Power - TB1 of Optional Power Supply/Battery Charger Module

FC-PSM Power Supply/Battery Charger Module: 120 VAC, 60 Hz, 1.0 amp.

FC-PSME Power Supply/Battery Charger Module: 220/240 VAC, 50 Hz, 0.5 amp.

Wire size: minimum #14 AWG with 600 V insulation.

AC Loss Relay - TB2 of Optional FC-PSM(E) Power Supply/Battery Charger Module

Operation: Relay transfers on loss of AC power to the Power Supply/Battery Charger Module for independent monitoring by DACT.

TB2 AC Loss relay contact rating: 2.0 amps @ 30 VDC (resistive), 0.6 amps @ 125 VAC (resistive)

Battery (lead acid only) - P2 of Optional FC-PSM(E) Power Supply/Battery Charger Module

Maximum Charging Circuit: Normal Flat Charge - 27.6V @ 0.800 amp

Maximum Charger Capacity: 17 Amp Hour battery. (FIRE•COMMAND•25/50 cabinet holds maximum 7 Amp Hour Battery. Larger batteries require Fire•Lite #BB-17F or other UL listed battery cabinet).

Command Input Circuits - TB2 Terminals 3(+) & 4(-) and TB5 Terminals 3(+) & 4(-)

CMD1 and CMD2 Command Input Circuits on Terminals 3 and 4. Terminal 1(-) and 2(+) are output terminals which provide feed through of the NAC circuits to NAC devices downstream.

Power-limited and supervised circuitry

Operation: Both circuits independently field programmable to activate amplifiers on NAC polarity reversal or contact-closure.

Normal Operating Voltage: 10.5 - 29 VDC (UL tested range: -15%, +10%)

NAC Reverse Polarity Current: 1.6 mA maximum.

Contact Closure Operation Current (requires 4.7K, ¼ watt End-of-Line Resistor P/N 27072): 6.6 mA maximum

Standby Current: n/a

Audio Amplifier Module - Standard Amp plugs into P4 of main circuit board, optional Amp (FC-AAM25) plugs into P3 of main circuit board

Backup Audio In - TB2, Terminals 1 & 2 (Out Terminals 3 & 4)

Operation: Optional amplifier provides backup to standard amplifier. Switch S1 on the backup amplifier must be 'ON' and jumpers placed from backup amplifier TB2 Terminal 3 to standard amplifier TB2 Terminal 1 and from backup amplifier TB2 Terminal 4 to standard amplifier TB2 Terminal 2. Refer to Chapter 5 for additional information.

Speaker Circuit - TB1 Terminals 3(+) & 4(-) Style Y, 5(+) & 6(-) Style Z, 1 & 2 Shield (Standby and Alarm Polarity Shown)

Power-limited circuitry

Operation: Circuit can be wired Style Y or Style Z

Normal Operating Voltage: 25 V_{RMS} (70.7 V_{RMS} operation possible by plugging optional FC-XRM70 conversion module into P1 of audio amplifier).

Output Power: 25 watts (20 watts when background music is employed).

Maximum total capacitance for each speaker circuit: 250 uF.

End-of-Line Resistor for Style Y circuit: Model R-20K, ½ watt P/N 75477.

Master CMD Out - TB6 Terminals 1(-) & 2(+)

Provides trigger for additional units. Will drive MR-101C or MR-201C relays (manufactured by Air Products and Controls) to provide alarm relay contacts.

Supervised and power-limited circuitry

Operation: Output reverses polarity on activation of Manual Evacuate switch or when either CMD1 or CMD2 are activated (in alarm)

Normal Operating Voltage: 24 VDC regulated, filtered. Reverse Polarity Current: 60 mA maximum.

Standby Voltage: -5 VDC. Short Circuit Current: 0.5 mA. Maximum Line Resistance: 130 ohms.

Specific Application Power - TB4 Terminals 1(-) & 2(+)

Up to 35 mA @ 24 VDC is available for powering control modules and associated End-of-Line power supervision relays.

Power-limited circuitry. Refer to Appendix D for compatible devices.

Form-C Trouble Relay - TB1

TB1 Form-C relay contact rating: 2.0 amps @ 30 VDC (resistive), 0.6 amps @ 125 VAC (resistive).

External Audio Input

RCA Jack Input (female connector)

Input Impedance: 3K ohms maximum

Input Voltage: 700 mV_{RMS} maximum

Input Current: 1 mA maximum @ 700 mV

Requires a preamplifier output. Mates to an RCA phono 'plug' - 3mm diameter, 10mm length, 9mm shell diameter.

1.3 Controls and Indicators

Front Panel Switches:

- Two Position Toggle Switch:
 - ✓ MANUAL EVACUATE - up position (latching)
 - ✓ MESSAGE OVERRIDE (microphone paging) - down position (momentary)
- TROUBLE SILENCE (REC) - momentary depression silences the local piezo when system is in trouble condition. Switch is also used for recording customized messages. See “S1 DIP Switch Settings” on page 15 and 2.2“S5 DIP Switch Settings” on page 16 for additional information on recording messages.
- MESSAGE PLAYBACK - for reviewing recorded message (requires optional FC-LPS module).

FIGURE 1-3:Controls and Indicators

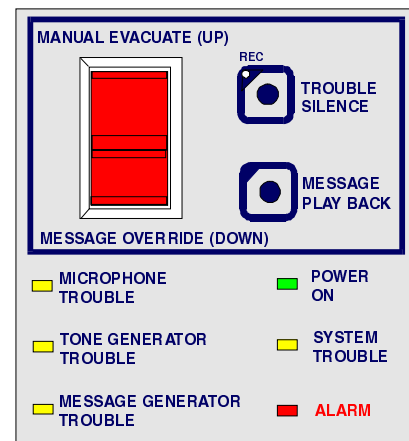

2550D5FC0DR

LEDs (visible with panel door closed):

- Power On - green LED
- System Trouble - yellow LED
- Alarm - red LED
- Microphone Trouble - yellow LED
- Tone Generator Trouble - yellow LED
- Message Generator Trouble - yellow LED
- Record LED (REC) - green LED

1.4 Circuits

Input Circuits - CMD1 and CMD2

- The two input circuits are independently field programmable to accept Notification Appliance Circuits or normally open contacts. Terminals are provided to allow feed-through of the NACs, allowing placement of the VECP anywhere along a Notification Appliance Circuit. A trouble on the VECP will cause relay contacts at the out terminals of CMD1 to open, causing an NAC circuit trouble at the FACP. *Note: The VECP will not open the out terminals while in alarm. Monitoring VECP troubles while in alarm requires use of independent trouble relay at TB1.*
- Programming CMD1 and/or CMD2 for activation on contact closure will allow activation of the amplifiers on a normally open contact transfer to the closed condition. Contact wiring is supervised for open conditions. A short will cause amplifier activation (contact closure).

RCA Jack

- RCA Jack provides convenient connection to an audio source such as a tape player for recording a new digital message. It may also be used for background music if approved by local AHJ.

Output Circuits

- Special Application Power Output, 35 mA @ 24 VDC.
- Optional Power Supply/Battery Charger FC-PSM(E) module provides power for the main circuit board in standby and alarm at maximum power.
- The optional FC-PSM(E) module also provides a 24 Volt Battery Charger (up to 17 AH batteries) @ 800 mA maximum.

Notification Appliance Circuit

- One NAC Speaker Circuit Style Y or Style Z with each FC-AAM25 amplifier module.

Relays

- One Form-C Trouble Relay. Contacts are rated 2.0 amps @ 30 VDC (resistive) and 0.6 amps @ 125 VAC (resistive)
- When optional Power Supply/Battery Charger module is installed, one Form-C AC Loss relay is provided on the module. Contacts are rated 2.0 amps @ 30 VDC (resistive) and 0.6 amps 125 VAC (resistive).

P1 and P5 Connectors (future use)**Local Speaker**

- Connector P2 provides a connection for an optional, removable local speaker P/N: FC-LPS, to be used for reviewing the digital message without broadcasting over the system speakers. Refer to Figure 3-18, "Installation of Speaker Module," on page 31. This option module must be installed to take advantage of the Playback feature. (The FC-LPS must be removed after use).

1.5 Components

Main Circuit Board

The Master Unit main circuit board contains the system's CPU, tone generators, auxiliary 35 mA output, DIP switches for field programmable features, digital message recorder/generator, integral microphone input and preamplifier, other primary components and wiring interface components. One amplifier module is supplied mounted to the main circuit board. Optional modules can be plugged in and mounted to the main circuit board. The main circuit board is delivered premounted in the cabinet.

FIGURE 1-4: Main Circuit Board

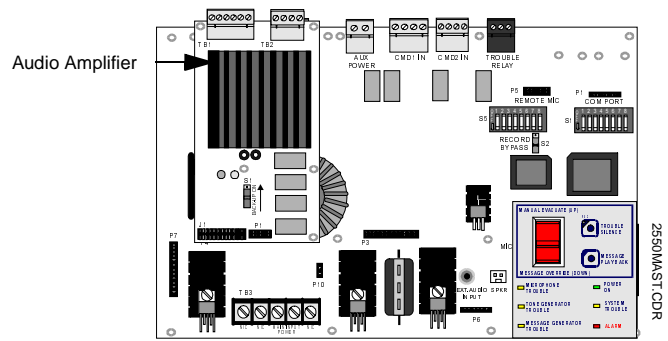

Audio Amplifier Module (FC-AAM25)

A single Audio Amplifier Module is installed in the FIRE•COMMAND•25/50. The amplifier provides 25 watts of power at 25 V_{RMS} . An optional module, P/N: FC-XRM70, converts the 25 V_{RMS} output to 70.7 V_{RMS} . One fully supervised and power-limited speaker circuit is provided on the amplifier module. The circuit can be wired for Style Y (Class B) or Style Z (Class A) operation.

LEDs are provided to indicate Amplifier Supervision (green indicates amplifier is functional) and Circuit Trouble (yellow indicates field wiring fault or amplifier fault). The LEDs are only visible with the panel door open.

FIGURE 1-5: Cabinet

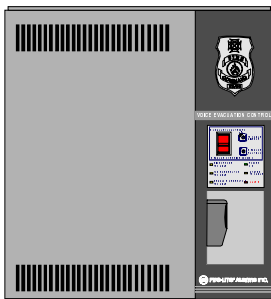

Cabinet

The cabinet is red with an attractive navy blue front overlay. A clear window allows viewing of status LEDs and location of microphone. The backbox measures 18.5" x 15.5" x 4.25" and provides space for two batteries (up to 7 Amp Hours).

Batteries

The cabinet provides space for 7 Amp Hour batteries (optional Power Supply/Battery Charger module installation required). If larger than 7 Amp Hour batteries are to be installed (17 AH maximum), use the Fire•Lite BB-17F battery box or similar UL listed battery box. Batteries and BB-17F battery box must be ordered separately.

Dress Panel

The Dress Panel is supplied standard with the system. It mounts to the cabinet with two supplied screws. The Dress Panel protects the user from high voltages and circuit boards from accidental damage. All system LEDs are visible with the Dress Panel installed.

FIGURE 1-6: Dress Panel

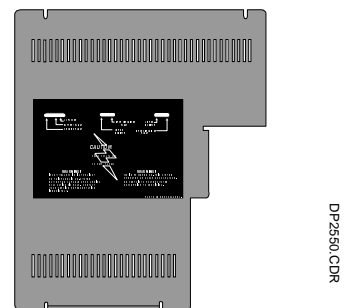

1.6 Optional Modules

FC-AAM25 Audio Amplifier Module

An optional second identical audio amplifier can be plugged into connector P3 located in the lower center of the main circuit board in the FIRE•COMMAND•25/50. This amplifier also provides 25 watts of power at 25 V_{RMS} and can therefore be used to expand system power to 50 watts (providing dual 25 watt speaker circuits) or it can be used as a backup amplifier. An option module can also be used to convert the 25 V_{RMS} output to 70.7 V_{RMS} .

Note: For ease of access, all wiring should be connected to the terminals on the main circuit board terminal blocks TB2, TB4, TB5 and TB6 prior to installing the secondary Audio Amplifier Module.

FC-XRM70 Transformer Module 70.7 V_{RMS}

This optional module plugs into connector P1 of the Audio Amplifier Module and provides conversion from 25 V_{RMS} to 70.7 V_{RMS} at full rated 25 watts output power.

FC-PSM(E) Power Supply/Battery Charger Module

This optional module plugs into connector P7 located in the lower left corner of the main circuit board thus allowing the VECP to be powered from its own internal power supply. The FC-PSM module is powered by 120 VAC, 60 Hz, 1.0 amp primary power and the FC-PSME module is powered by 220/240 VAC, 50 Hz, 0.5 amp primary power. An integral battery charger is capable of charging up to 17 Amp Hour batteries. Primary AC power to the FC-PSM(E) is constantly monitored. Upon loss of AC power or AC brownout, the AC Loss Relay contacts change state and the AC ON LED extinguishes. A switch option (S1) may be used to select immediate or 6 hour delay of AC Loss Relay transfer (for independent monitoring by DACT).

FC-LPS Local Playback Speaker

This optional speaker module plugs into connector P2 located in the lower right corner of the VECP main circuit board. This unit allows reviewing of the digital message locally without broadcasting it over the system speakers. The optional module must be installed in order to take advantage of the Playback feature. It may be temporarily used to test recorded messages. A mounting kit is included for this purpose. The FC-LPS cannot be permanently mounted in the enclosure and must be removed after use.

CHAPTER 2 *Field Programming*

The FIRE•COMMAND•25/50 VECP can be field programmed using option DIP switches S1 and S5 located in the upper right side of the main circuit board. It is recommended that tone selection, message repeat cycles and background music options be reviewed and approved by the local AHJ. Refer to the following illustration for details on DIP switch placement in the ON and OFF positions.

FIGURE 2-1:Field Programming DIP Switches

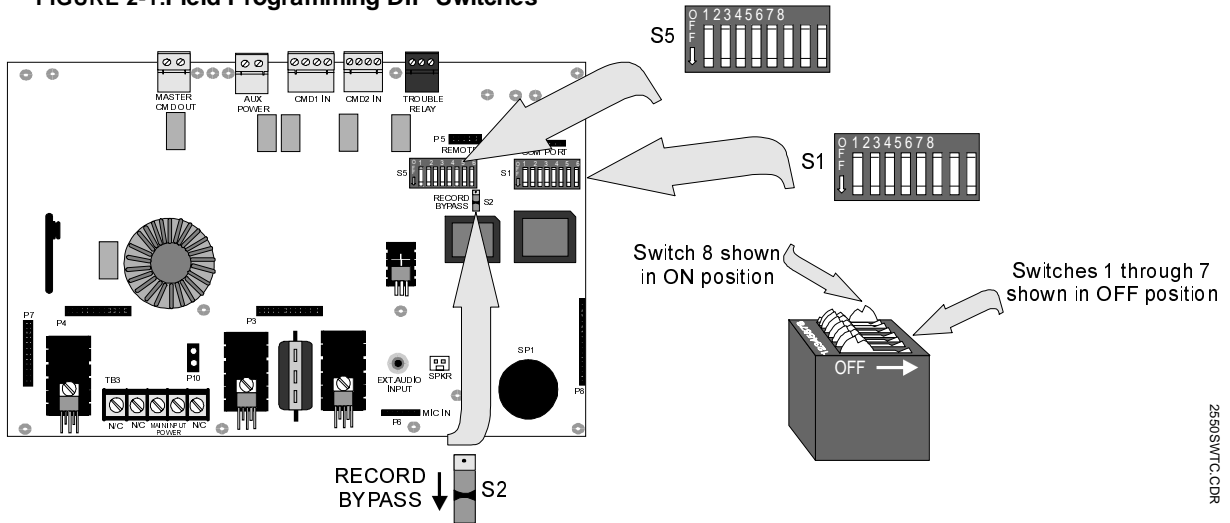

2.1 S1 DIP Switch Settings

- Switch 1 - Temporal pattern generated per ANSI S3.41 when Switch 1 is ON and Switches 2 and 3 are OFF
 OFF = No temporal pattern - tone generated as selected by Switches 2 and 3 (factory default setting).
 ON = Temporal pattern generated on steady tone. Switches 2 and 3 must be in the OFF position.
- Switches 2 and 3 - used to determine what tone will be transmitted over the speakers before and after the message is transmitted as well as the backup tone to be transmitted if the digital voice generator fails.

TABLE 2-1: Switch Settings for Tones

SWITCH 2	SWITCH 3	TONE TRANSMITTED BEFORE AND AFTER DIGITAL VOICE MESSAGE
OFF	OFF	STEADY
OFF	ON	SLOW WHOOP (factory default)
ON	OFF	Hi-Lo
ON	ON	CHIME

- Switch 4 - used to determine if the tone selected by S1 switches 2 and 3 will be generated before the message is transmitted:
 OFF = No tone before message
 ON = Tone before message (factory default setting)

- Switch 5 - used to determine if the tone selected by S1 switches 2 and 3 will be generated after the message is transmitted:
 OFF = No tone after message
 ON = Tone after message (factory default setting)
- Switch 6, 7 and 8 - used to determine the number of times the voice message will repeat.

TABLE 2-2: Switch Settings for Message Repeat

SWITCH 6	SWITCH 7	SWITCH 8	NUMBER OF TIMES TO REPEAT DIGITAL VOICE MESSAGE
OFF	OFF	OFF	Tone only, no voice ¹
ON	OFF	OFF	3
OFF	ON	OFF	4
ON	ON	OFF	6 (factory default)
OFF	OFF	ON	8
ON	ON	ON	INFINITE (until FACP NAC or Manual Evacuate switch is reset)

1. Some jurisdictions require tone evacuate only. This option prevents voice messages from being generated. Verify with local AHJ if voice message is allowed and the number of times the message may be repeated.

2.2 S5 DIP Switch Settings

- Switch 1 - Future use
- Switch 2 - Provides two distinct functions for message recording and speaker circuit selection as follows:

Message Recordings:

When recording a message to be played back by the Digital Message Generator, Switch 2 is used to set the number of messages to be recorded:

OFF = one 60 second 'fire' message (factory default setting).

Note: Can also be recorded as one evacuate message in two languages; one language recorded immediately after the first language.

ON = two 30 second messages.

Note: Both messages can be 'fire' related or one may be 'nonfire' related, i.e. 'fire evacuation' and 'fire clear' messages or 'fire' and 'tornado warning' messages.

Speaker/Message Selection

During panel operation, Switch 2 is also used to determine which speaker circuit(s) will be activated by Command Input Circuits 1 & 2 and which message will be transmitted. In order for the speaker circuit select function to operate, be certain to install the second amplifier and do not select the backup feature.

Switch 2 OFF (factory default setting) as shown in following Table:

TABLE 2-3: One 60 Second Message - Amp Selected

CMD1	CMD2	AMP1	AMP2
0	0	OFF	OFF
0	1	OFF	FIRE MESSAGE
1	0	FIRE MESSAGE	OFF
1	1	FIRE MESSAGE	FIRE MESSAGE

Command Input #1 (CMD1) activates only speaker circuit #1 and transmits up to a 60 second 'fire' message

Command Input #2 (CMD2) activates only speaker circuit #2 and transmits up to a 60 second 'fire' message

Switch 2 ON as shown in following Table:

TABLE 2-4: Two 30 Second Messages - Message Selected

CMD1	CMD2	AMP1	AMP2
0	0	OFF	OFF
0	1	MESSAGE #2	MESSAGE #2
1	0	MESSAGE #1	MESSAGE #1
1	1	MESSAGE #1	MESSAGE #1

Command Input #1 (CMD1) activates speaker circuits 1 & 2 and transmits up to a 30 second 'fire' message over both speaker circuits.

Command Input #2 (CMD2) activates speaker circuits 1 & 2 and transmits up to a 30 second 'nonfire' or second fire related message over both speaker circuits.

- Switch 3 - controls whether background music can be played over the speakers from the RCA Jack Input.
 OFF = Background music disabled (factory default setting)
 ON = Background music enabled

Note: The FC-PSM(E) module must be installed and powering the VECP when background music is enabled. Not UL approved when powered through TB3 main input power. NFPA 72 requires that speakers used as alarm notification appliances on fire alarm systems not be used for nonemergency purposes. Consult with the Local AHJ for authorization to use background music. Only 20 watts of power can be supplied per amplifier if background music is enabled.

- Switch 4 - Future use
- Switch 5 - used to determine what will activate the Command Input #1.
 OFF = Activation on NAC polarity reversal (factory default setting)
 ON = Activation on contact closure
- Switch 6 - used to determine what will activate the Command Input #2.
 OFF = Activation on NAC polarity reversal (factory default setting)
 ON = Activation on contact closure
- Switch 7 - used to determine the source being used to record the digital voice message.
 OFF = Record from Microphone (factory default setting)
 ON = Record from External Audio Input (RCA Jack)

- Switch 8 - used to enable recording of digital voice message.
OFF = Recording not permitted, Trouble Silence/Rec key used for trouble silence (factory default setting)
ON = Recording permitted, Trouble Silence/Rec key used to record voice message. Switch must be restored to default setting upon completion of recording.

2.3 S2 - Record Bypass Switch

This switch, when placed in the down position, prevents accidental erasure of stored voice messages. See “Operating Instructions” on page 32 for additional information.

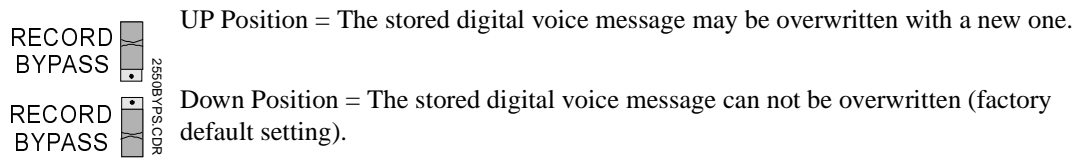

CHAPTER 3 *Installation*

3.1 Mounting Options

The cabinet may be surface or semi-flush mounted. Semi-flush mounting requires use of the FC-TR trim ring illustrated in Figure 3-2. The door is removable during the installation period by opening and lifting it off the hinges. The cabinet mounts using two key slots at the top of the backbox and two additional 0.250" diameter holes located at the bottom.

Carefully unpack the system and check for shipping damage. Mount the cabinet in a clean, dry, vibration-free area where extreme temperatures are not encountered. The area should be readily accessible with sufficient room to easily install and maintain the panel. Locate the top of the cabinet approximately five feet above the floor with the hinge mounting on the left. Determine the number of conductors required for the devices to be installed. Sufficient knockouts are provided for wiring convenience. Select the appropriate knockout(s) and pull the required conductors into the box. Note that there are no knockouts on the back of the cabinet. All wiring should be in accordance with the National and/or Local codes for fire alarm systems.

FIGURE 3-1:VECP Cabinet

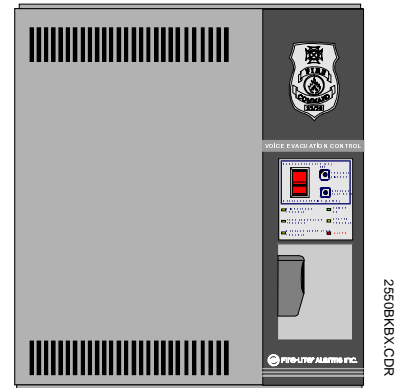

3.2 Backbox Installation

Surface Mounting

- ✓ Open the door and lift the door off the pin hinges.
- ✓ Mark and predrill holes for the top two backbox keyhole mounting bolts using the dimensions shown.
- ✓ Install two upper fasteners in the wall with the screw heads protruding.
- ✓ Using the upper 'keyholes', mount the backbox over the two screws.
- ✓ Mark and drill the lower two holes.
- ✓ Install the remaining fasteners and tighten all fasteners to complete backbox mounting.

Semi-flush Mounting Using Optional FC-TR Trim Ring

- ✓ Open Trim Ring hardware kit which contains six (6) screws and six (6) drywall anchors.
- ✓ Remove VECP cabinet door by sliding door upward off pin style hinges.
- ✓ Place FC-TR trim ring around VECP cabinet making certain that the hinge cut-outs are on the left hand or hinged side of the cabinet.
- ✓ Making certain that the trim ring is placed around the VECP cabinet maintaining an equal distance from all four sides of the cabinet, mark the centers of all six FC-TR mounting holes.
- ✓ Remove the trim ring and drill the holes where marked on the wall.
- ✓ Install the six (6) supplied drywall anchors into the drilled holes.
- ✓ Place the FC-TR trim ring around the VECP cabinet and secure in place using the six (6) supplied screws.

FIGURE 3-2:FC-TR Trim Ring

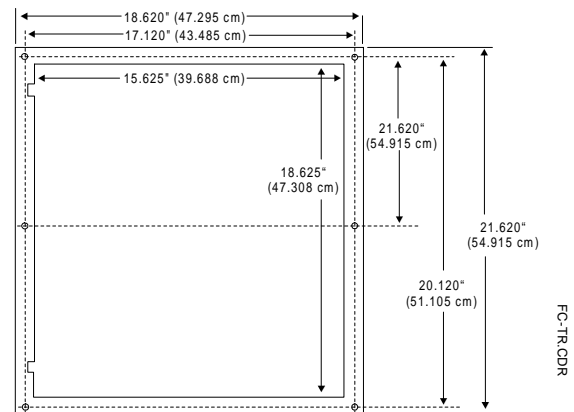

Draw wires through the respective knockout locations.

FIGURE 3-3: Cabinet Dimensions & Knockout Locations

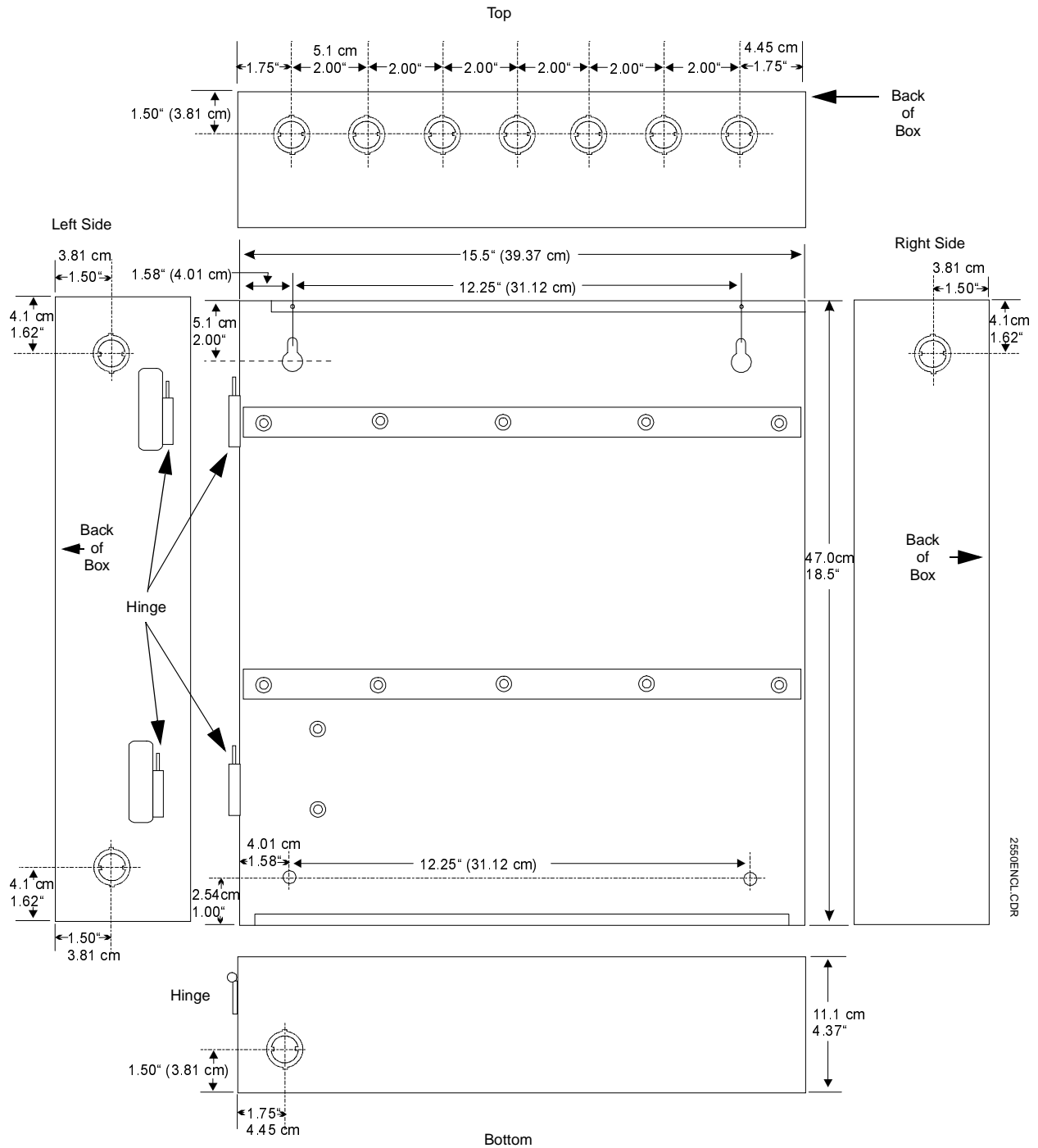
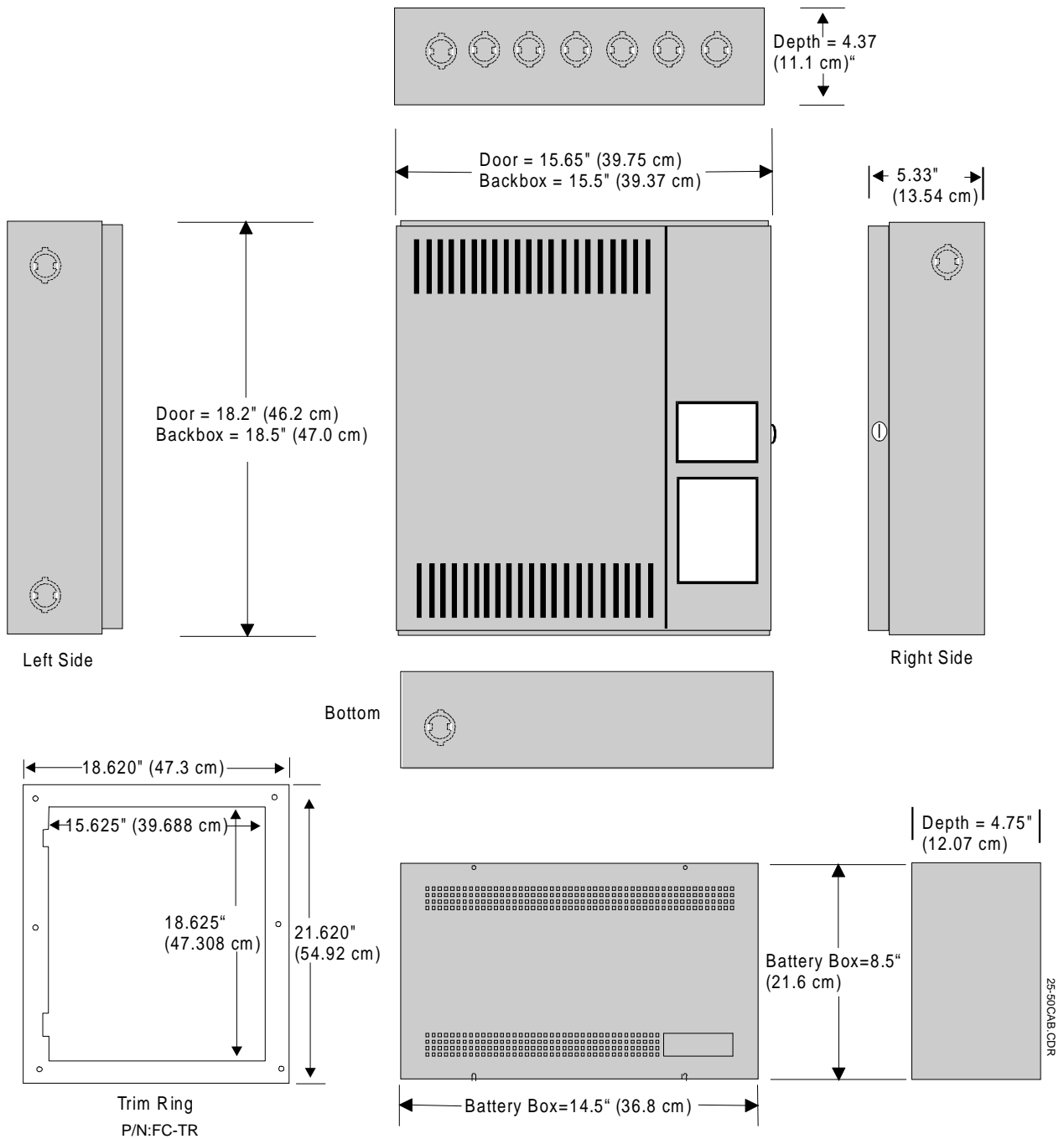

FIGURE 3-4:VECP Backbox and Battery Box



1. BB-17F is required when using the internal FC-PSM(E) Power Supply/Battery Charger and greater than 7 AH batteries.
2. Mount the FIRE•COMMAND•25/50 (VECP) cabinet to the wall
3. Remove knockouts on bottom of VECP cabinet and top of BB-17F.
4. Using conduit, hang the BB-17F from the VECP cabinet making sure there is at least ½" of clearance between the two cabinets.
5. Anchor the BB-17F to the wall.

3.3 Operating Power

CAUTION: Several different sources of power can be connected to this panel. Disconnect all sources of power before servicing. The panel and associated equipment may be damaged by removing and/or inserting cards, modules or interconnecting cables while this unit is energized.

Main Input Power - Connections Made Only if Optional FC-PSM(E) Power Supply is Not Installed

The VECP requires filtered 24 VDC nominal power which can be supplied by a UL listed host FACP or a remote power supply UL listed for Fire Protective Signaling Service, such as the FCPS-24F(E). Refer to Appendices for wiring information. Supplied power must be from a power-limited source. Run a pair of wires from a regulated 24 VDC output on the host FACP or remote power supply to the VECP's TB3 Terminals 3(-) & 4(+). The jumper on P7 pins 1 & 2 must remain installed. Be certain to connect a separate solid earth ground to the transformer mounting stud to ensure proper panel operation and lightning and transient protection. Be certain to include the FIRE•COMMAND•25/50 power requirements in the FACP or remote power supply battery calculations.

Internal Power Supply/Battery Charger FC-PSM(E)

An optional power supply is available to allow stand-alone capabilities and is required for background music applications. AC power connections are made to the FC-PSM(E) Internal Power Supply/Battery Charger. Primary power source is 120 VAC, 60 Hz, 1.0 amp for the FC-PSM Power Supply/Battery Charger module and 220/240 VAC, 50 Hz, 0.5 amps for the FC-PSME Power Supply/Battery Charger module. Run a pair of wires (with ground conductor) from the protected premises main breaker box to TB1 of the FC-PSM(E). As per National Electric Code, use 14 AWG (1.6 mm O.D.) or heavier gauge wire with 600V insulation. No other equipment may be connected to this circuit. In addition, this circuit must be provided with overcurrent protection and may not contain any power disconnect devices. A separate Earth Ground connection must be made to ensure proper panel operation and lightning and transient protection. Connect the Earth Ground wire (minimum 14 AWG) to one of the transformer mounting studs. Do not use conduit for the Earth Ground connection since this does not provide reliable protection.

CAUTION: When the FC-PSM(E) Power Supply/Battery Charger is installed, there should be no other connections to TB3 of the VECP.

Secondary Power Source (Batteries) When Power Supply/Battery Charger FC-PSM(E) is Installed

Observe polarity when connecting the battery. Connect the battery cable to P2 on the Internal Power Supply Battery Charger module using the plug-in connector and cable provided. The battery charger is current-limited and capable of recharging sealed lead acid type batteries (See Figure 3-5 for battery orientation). The charger shuts off when the system is in alarm. See Appendix A for calculation of the correct battery rating.

CAUTION: Battery contains sulfuric acid which can cause severe burns to the skin and eyes, and can destroy fabrics. If contact is made with sulfuric acid, immediately flush the skin or eyes with water for 15 minutes and seek immediate medical attention.

FIGURE 3-5: Operating Power Connections

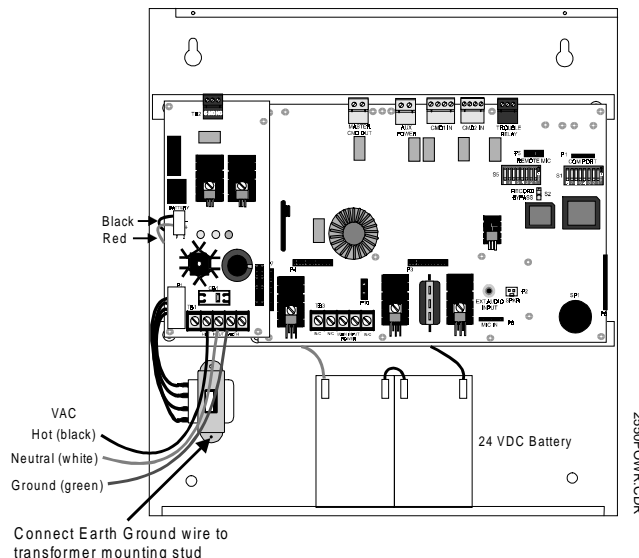

3.4 Auxiliary DC Power Output Connections

The Auxiliary DC power output is power-limited.

FIGURE 3-6:Auxiliary Power Connection

Special Application Power (35 mA @ 24 VDC) is nonresettable power suitable for powering control modules and End-of Line Power supervision relays. See Appendix D for compatible devices.

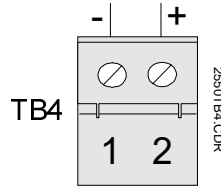

3.5 Input Circuits

The VECP has two Command Input circuits (CMD1 and CMD2), which are used to activate the panel amplifiers which, in turn, transmit an audio signal over the system speakers. All field wiring for each circuit is power-limited and supervised for opens and ground faults.

Each CMD Command Input circuit can be independently field programmed to be triggered by a contact closure or by the reverse polarity of a Notification Appliance Circuit. CMD input and output terminals are provided to allow placement of the VECP anywhere along a Notification Appliance Circuit allowing nondedicated use of host FACP NAC for triggering. CMD1 has relay contacts (maximum current 2.0 amps) before the out terminals which will open the outgoing NAC circuit during a VECP trouble condition. This causes an NAC trouble at the host FACP.

Note that the Command Input Circuit configurations can be independently set so that both circuits are triggered by the same type of input or by different types of inputs (Refer to Figure 3-7 on page 23).

FIGURE 3-7:Command Input Circuits

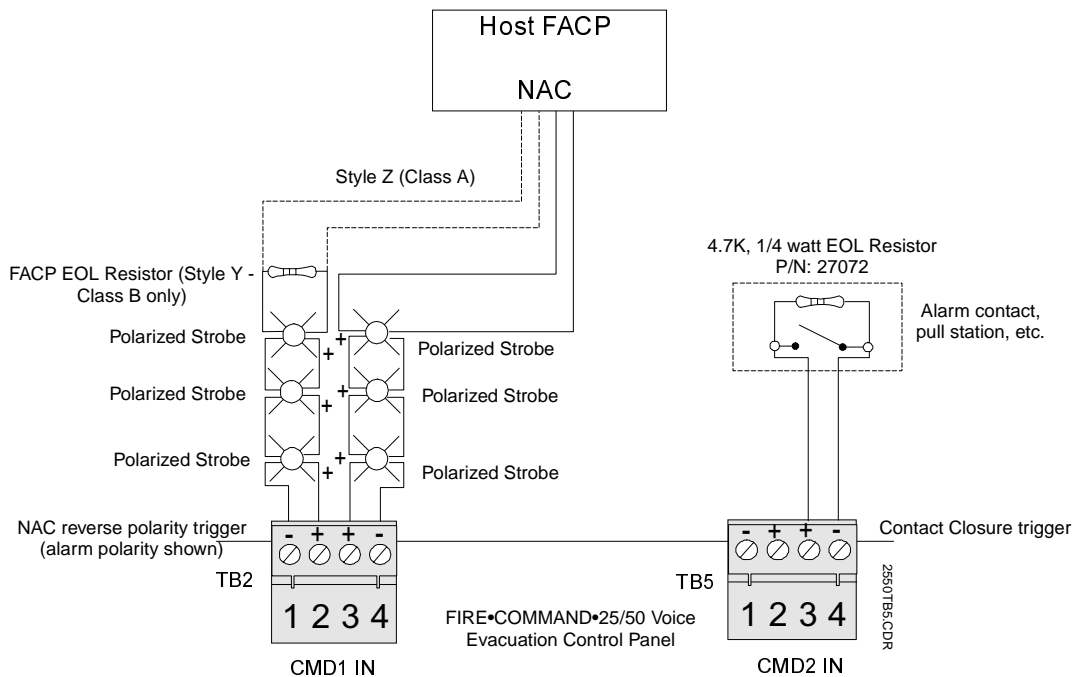

3.6 Output Circuits

Master Command Output Bus

The Master Command Output is a 24 VDC reverse polarity output (TB6) which can be used to trigger additional FIRE•COMMAND•25/50 units. The Master Command Output will activate on any alarm condition as triggered by the Command Inputs CMD1 or CMD2, or when the manual evacuate switch is ON. It will not be active when the Message Override switch is ON during general paging.

When connecting the Master Command Output of the main panel to the Command Inputs of other FIRE•COMMAND•25/50 panels or to other devices, the wiring must be supervised by a 4.7K EOL resistor connected across the out terminals of Command Input #1 on the last panel.

In Example 1 illustrated below, the audio output from each unit is not synchronized. Each VECP may generate a different audio message if desired. Paging must be done at each individual panel's microphone.

FIGURE 3-8: Example 1 - Activating Multiple VECPs with Master CMD Output Bus

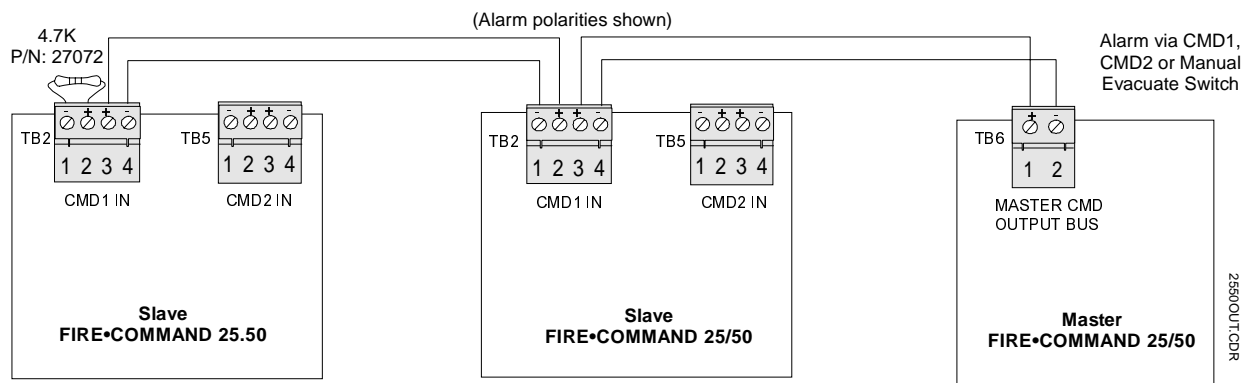

The maximum line resistance from the main VECP to the last VECP is 130 ohms (65 ohms per conductor).

FIGURE 3-9: Example 2 - Activating MR-101C (or MR-201C) with Master CMD Output Bus

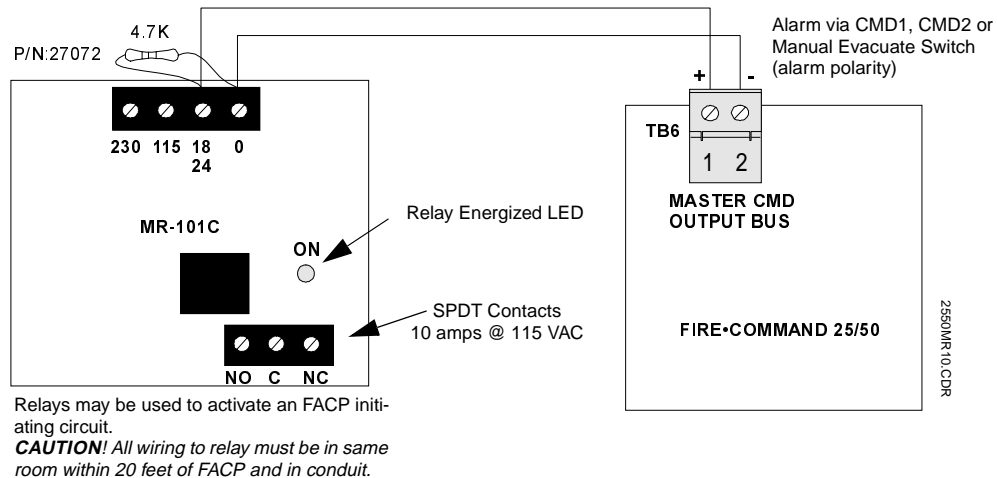

The MR-101C (one Form-C relay) and MR-201C (two Form-C relays), which are manufactured by Air Products and Controls, include an enclosure.

Trouble Relay - TB1

The main circuit board provides a Form-C Trouble relay, for independent monitoring, rated for 2.0 amps @ 30 VDC (resistive) and 0.6 amp @ 125 VAC (resistive). This relay is 'fail safe', meaning that it is normally energized. Should system power via FC-PSM(E) or main input power shut off, this relay will deenergize, transferring its contacts.

FIGURE 3-10: Trouble Relay

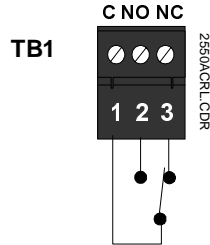

AC Power Loss Relay - TB2

The optional FC-PSM(E) internal Power Supply/Battery Charger Module provides a Form-C AC Power Loss relay rated for 2.0 amps @ 30 VDC (resistive) and 0.6 amps @ 125 VAC (resistive).

FIGURE 3-11: AC Power Loss Relay

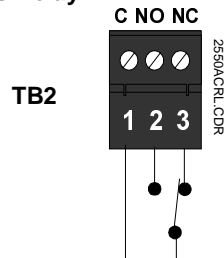

Notification Appliance Circuit (Speakers)

Each Amplifier Module provides one Notification Appliance Circuit for speakers. The circuit can be wired Style Y (Class B) or Style Z (Class A). Each supervised and power-limited circuit is capable of 25 watts of power. The maximum total capacitance for each speaker circuit cannot exceed 250 uF. Refer to the Fire•Lite Device Compatibility Document for a listing of compatible speakers.



CAUTION: Match proper polarity connections to field wiring and speakers. Polarity shown is in the standby and alarm conditions.

FIGURE 3-12: Speaker Circuit Connections

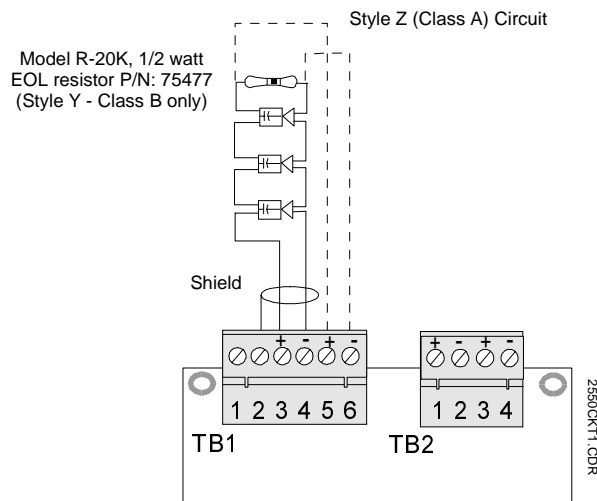

Shielded cable is not required, however, shielded cable will reduce RFI/EMI emissions and susceptibility. For additional information, refer to Appendix E.

3.7 UL Power-limited Wiring Requirements

Power-limited and nonpower-limited circuit wiring must remain separated in the cabinet. All power-limited circuit wiring must remain at least 0.25" away from any nonpower-limited circuit wiring. Furthermore, all power-limited and nonpower-limited circuit wiring must enter and exit the cabinet through different knockouts and/or conduits. A typical wiring diagram for the FIRE•COMMAND•25/50 is shown below.

FIGURE 3-13: Typical Wiring Diagram for UL Power-limited Requirements

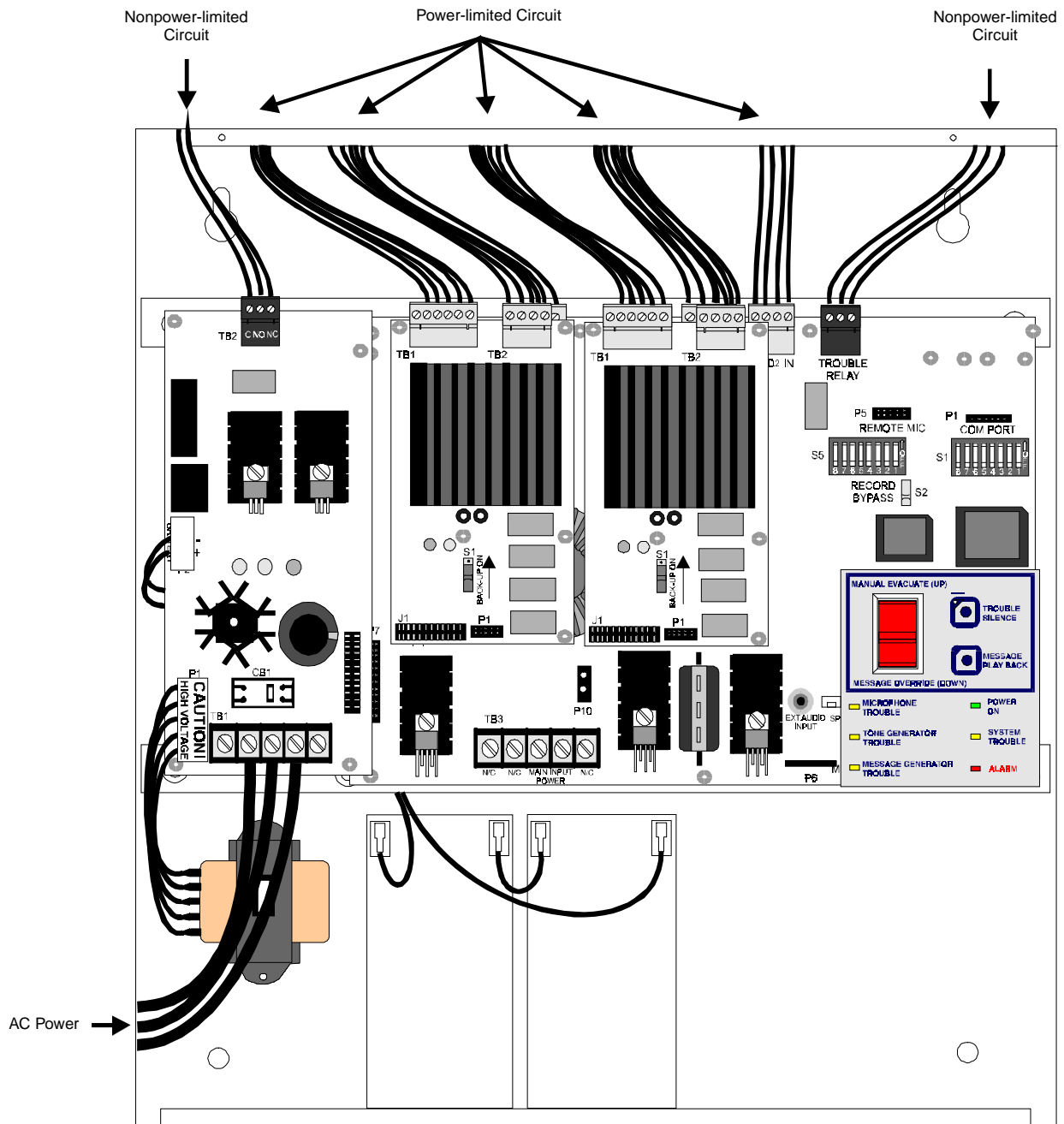

Wiring to TB3 must be from power-limited source and enter/exit the cabinet through the lower left corner. (Wiring must not be connected to TB3 when the FC-PSM(E) module is being used to power the VECP as shown).

3.8 Installation of Option Modules

3.8.1 Audio Amplifier Module (FC-AAM25)

The optional audio amplifier module is identical to the module provided with the factory standard panel configuration. It can be used to provide a second 25 watt speaker circuit, increasing the total VECP power to 50 watts, or it can be used as a backup amplifier. LEDs on the amplifier module are for Amp Supervision (green - indicates amp functional) and Circuit Trouble (yellow - indicates wiring fault or amplifier fail). Connector J1 of the audio amplifier module plugs into connector P3 located at the bottom center of the main circuit board.



Caution: Before installing any modules, make certain all power (AC and DC) has been removed.

1. For ease of access, all wiring should be connected to the terminals on the main circuit board terminal blocks TB2, TB4, TB5 and TB6 prior to installing the secondary Audio Amplifier Module.
2. Remove mounting screw shown, from the main circuit board, and save (refer to illustration below).
3. Install one supplied metal standoff in location from which mounting screw was removed in Step 2.
4. Install the Audio Amplifier Module by carefully aligning the amplifier's J1 connector with the P3 connector on the main circuit board. Press the Module securely into place making certain not to bend or break any connector pins.
5. Secure the Audio Amplifier Module with the supplied screws plus the screw removed in Step 2. It is important to secure the module with the metal screws in order to help protect against electrical transients.
6. Configure the Audio Amplifier for primary or backup amplifier operation by setting switch S1 on the amplifier:
 - 1) Position switch S1 in the DOWN position for primary operation which adds the new amplifier's 25 watts to total system power (50 watts total).
 - 2) Position switch S1 in the UP 'Backup On' position to configure the amplifier as a backup in the event the primary amplifier fails.
7. Check to make certain the factory installed jumpers are in place on P1 of the Audio Amplifier Module(s). Do not remove unless installing the FC-XRM70 Transformer Module. Refer to Figure 3-15 on page 28.
8. Connect field wiring to newly installed amplifier. Refer to Figure 3-12 on page 25 for illustration of speaker connections if amplifier is being used to expand system power to 50 watts (i.e. providing dual 25 watt speaker circuits). Refer to Figure 5-2 on page 41 for illustration of connections if amplifier is being used as a backup.

FIGURE 3-14: Installation of Optional Audio Amplifier

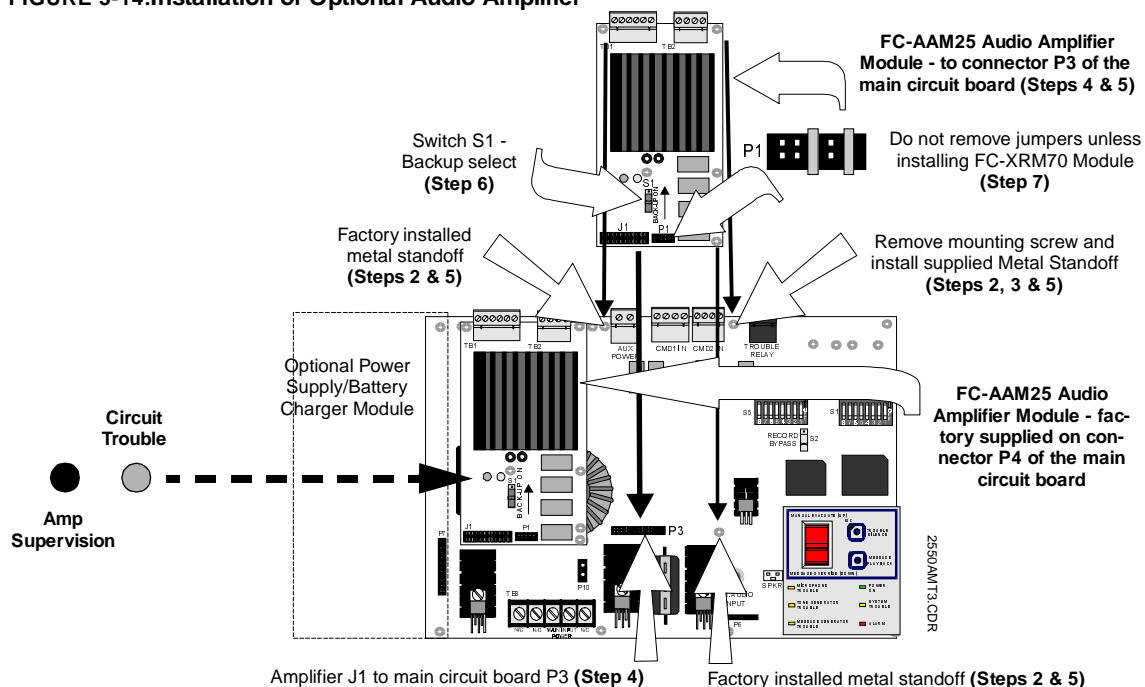

3.8.2 70.7 V_{RMS} Transformer Module (FC-XRM70)

The 70.7 V_{RMS} Transformer Module can be used to convert the 25 V_{RMS} amplifiers for installations where 70.7 V_{RMS} speakers already exist or are to be installed. Transformer connector J1 connects to amplifier connector P1.



Caution: Before installing any modules, make certain all power (AC and DC) has been removed.

1. Carefully remove the FC-AAM25 Audio Amplifier Module(s) from the main circuit board. Refer to Figure 3-14 on page 27 for installation procedures and reverse the steps.
2. Install the three metal standoffs supplied with the FC-XRM70 Module by inserting the threaded male end of each standoff into the three holes on the component side of the FC-AAM25 Audio Amplifier Module(s). Secure each standoff in place with a supplied nut. Refer to Figure 3-15 for the location of the mounting holes.
3. Reinstall the Audio Amplifier Module(s) following the procedure accompanying Figure 3-14.
4. Remove the two factory installed jumpers from connector P1 of the Audio Amplifier Module(s). Refer to the illustration in Figure 3-15.
5. Carefully align the J1 connector on the FC-XRM70 Transformer Module(s) with the P1 connector on the Audio Amplifier Module and press securely into place. Make certain the pins are properly aligned to prevent bending or breaking of pins.
6. Secure the FC-XRM70 Transformer Module(s) to the Audio Amplifier Module(s) with the supplied screws. It is important that the supplied metal screws be used in order to help protect against electrical transients.

FIGURE 3-15:70.7 V_{RMS} Transformer Module Installation

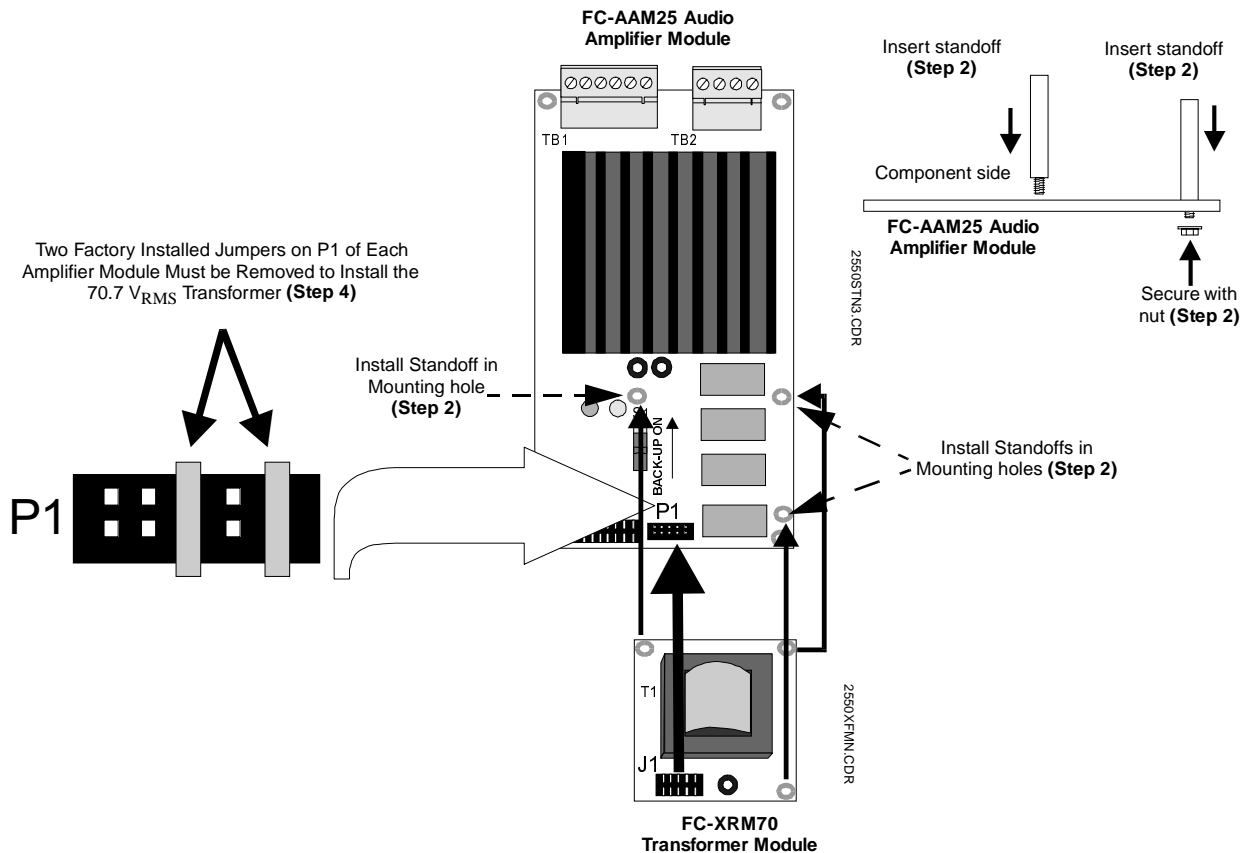

3.8.3 Power Supply/Battery Charger Module FC-PSM(E)

The optional Power Supply/Battery Charger Module can be used to provide stand-alone power to the VECP. The FC-PSM module is powered by 120 VAC and the FC-PSME module is powered by 220/240 VAC. In addition to supplying operating power, the module is capable of charging 7 AH to 17 AH batteries. LEDs on the module indicate AC On (green), Battery Trouble (yellow) and Ground Fault (yellow). S1 is the AC Fail Delay switch. When positioned to the right, in the AC Fail Delay position, the panel will delay the deactivation of the AC Power Fail relay for independent monitoring by a DACT for six hours. Connector J1 of the Power Supply module plugs into connector P7 located in the lower left corner of the main circuit board. Make certain to remove the factory installed jumper from P7 on the main circuit board before installing the Power Supply Module.

TB2 provides AC power fail relay contacts which transfer on loss of AC power. Batteries can be connected to the P2 connector on the Power Supply Module. Up to 7 AH batteries can be installed in the cabinet. Larger batteries must be installed in an external UL listed battery cabinet such as the Fire•Lite BB-17F.



Caution: Before installing any modules, make certain all power (AC and DC) has been removed.

1. Remove the two mounting screws from the top left and bottom left corners of the main circuit board.
2. Install two supplied short metal standoffs (one threaded male end) by screwing them into the holes vacated in Step 1.
3. Install the two supplied long metal standoffs (two threaded female ends) by screwing them onto the threaded mounting studs in the top and bottom mounting rails in the backbox. The mounting studs are located to the far left on each rail. Refer to Figure 3-17 Backbox illustration.
4. Remove the factory installed jumper from connector P7 of the main circuit board. P7 is located on the bottom left corner of the main circuit board as illustrated in Figure 3-16.
5. Carefully align connector J1 on the FC-PSM(E) Module with connector P7 on the main circuit board and press the FC-PSM(E) securely into place being certain not to bend or break any connector pins.
6. Secure the FC-PSM(E) Module to the standoffs using the two screws removed in Step 1 and two supplied screws. It is important that the metal screws be used in order to help protect against electrical transients.
7. Continue with the FC-PSM(E) Transformer installation as described on the following page.

FIGURE 3-16: Installation of FC-PSM(E) Power Supply/Battery Charger Module

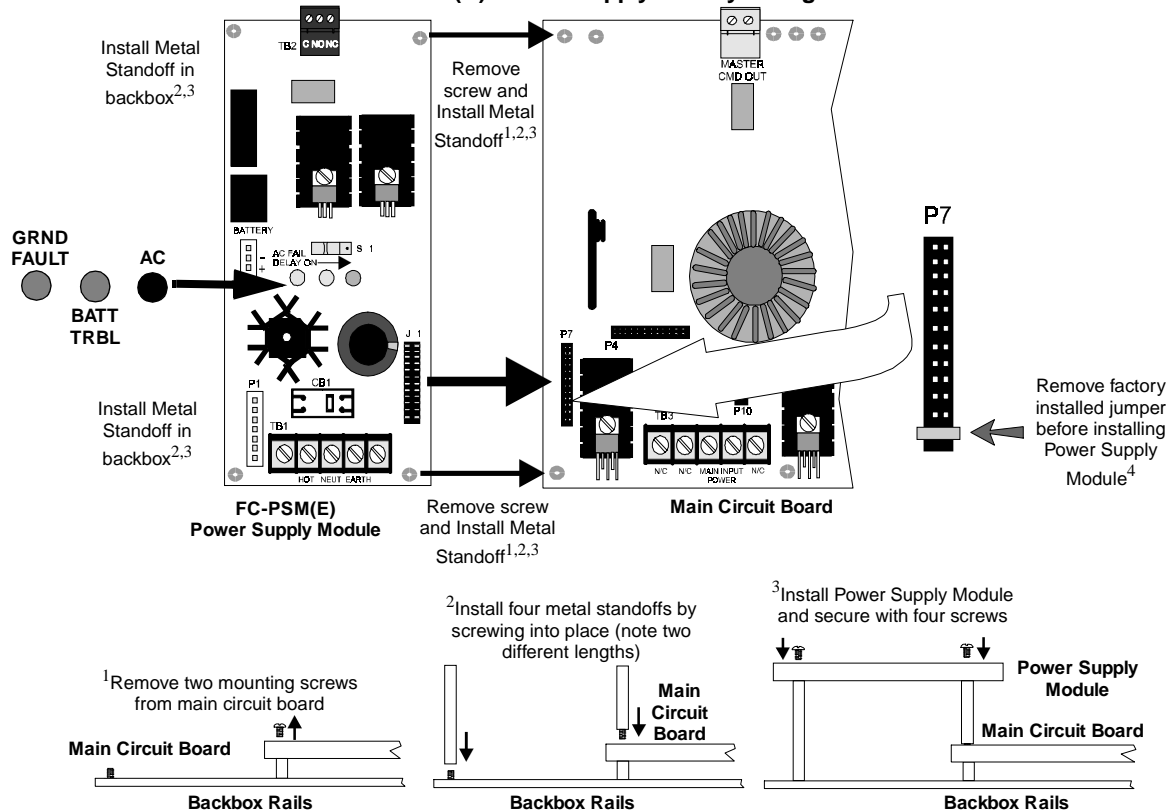

2550PWRM.CDR

2550STIND.CDR

3.8.4 Transformer Installation

Caution: Before installing any modules or cables, make certain all power (AC and DC) has been removed.

1. Locate two threaded mounting studs in the bottom left corner of the backbox (refer to backbox illustration below).
2. Position the XRM-24 (120 VAC) Transformer Assembly or XRM-24E (220/240 VAC) Transformer Assembly, over mounting studs, with cable assembly oriented to the left as illustrated below.
3. Secure the Transformer to the studs with the two supplied nuts. Do not tighten one of the nuts until the next step.
4. Connect a wire from a solid earth ground to one of the Transformer mounting studs and tighten the nut. This connection is necessary in order to provide proper lightning and transient protection for the panel.
5. Plug XRM-24(E) Transformer cable assembly into connector P1 which is located in the lower left corner of the FC-PSM(E) Module. Note that the Transformer cable connector is keyed to prevent incorrect connection.
6. Complete the installation by connecting the AC power wires to Hot, Neutral and Earth terminals of TB1 on the FC-PSM(E) Module.
7. If batteries are being used, connect the batteries (17 AH maximum) to connector P2 located to the left center of the FC-PSM(E) Module.
8. Apply power to the panel.

FIGURE 3-17: Installation of Power Supply Transformer

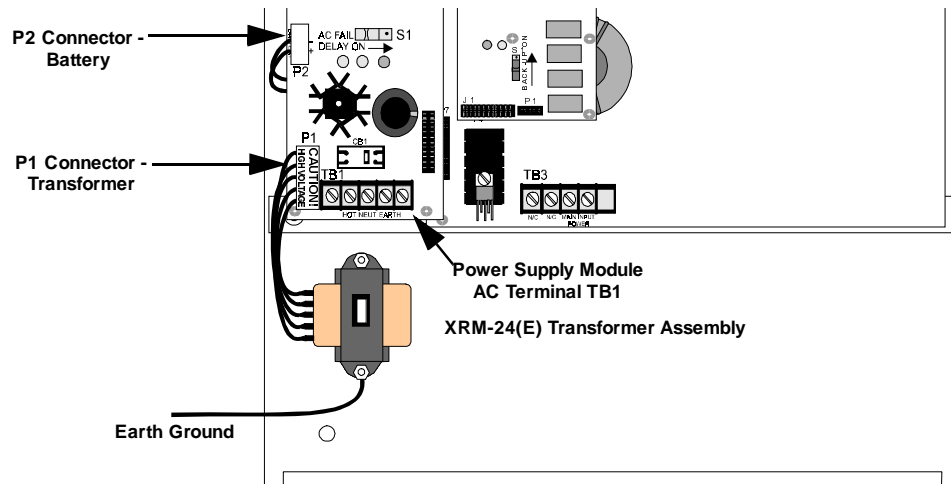

2550XMINT.CDR

Backbox

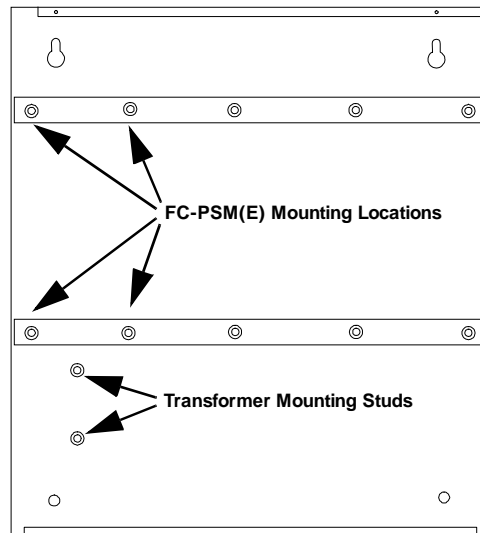

2550BXEN.CDR

3.8.5 Local Playback Speaker Module (FC-LPS)

The Local Playback Speaker Module can be used to monitor the recorded digital message without transmitting the message over the system speakers. The speaker module plugs into P2 of the main circuit board. This optional module is necessary to take advantage of the Playback feature.

The Speaker Module is connected by simply plugging the module connector into P2 of the main circuit board. The Speaker Module may be installed during the test period by using the supplied mounting hardware.

1. Remove the main circuit board mounting screw located to the right of power terminal block TB3.
2. Install the supplied metal standoff in the mounting hole just vacated in Step 1 and screw standoff into place.
3. Position the FC-LPS mounting bracket hole over the standoff and secure with screw removed in Step 1.
4. Plug the FC-LPS Local Playback Speaker Module's polarized connector into connector P2 on the main circuit board. P2 is located on the bottom right of the main circuit board near the Control/Indicator panel.
5. When testing is completed, remove the FC-LPS and standoff and reinstall the screw. The FC-LPS is not approved for permanent connection.

FIGURE 3-18: Installation of Speaker Module

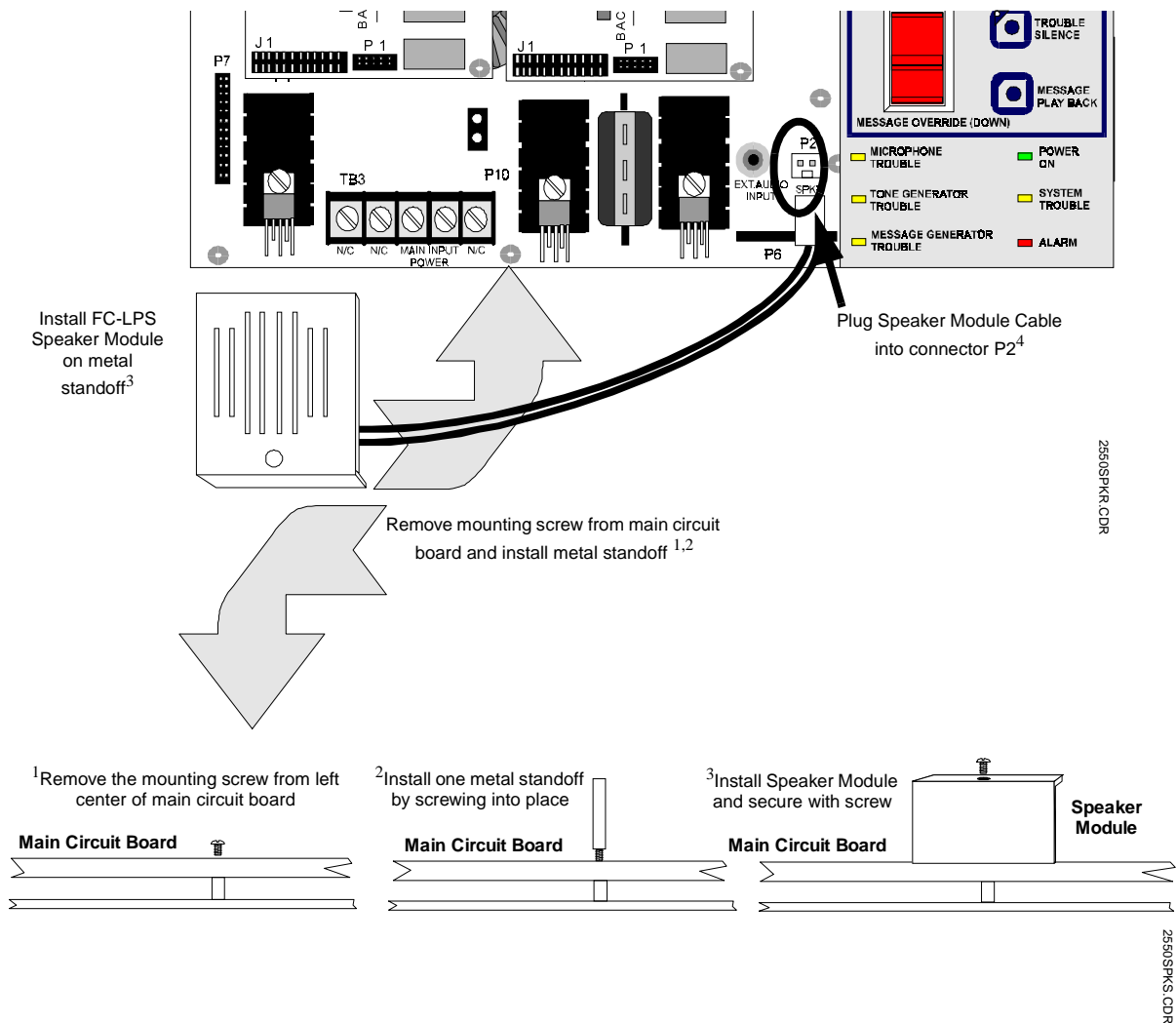

25505PKR.CDR

25505PKS.CDR

CHAPTER 4 *Operating Instructions*

4.1 Switches

4.1.1 Manual Evacuate/Message Override

Manual Evacuate/Message Override is a two position switch used for manually generating programmed evacuation tones/messages or for paging. It is visible through the window of the closed backbox door. The door must be unlocked and opened for access to the switch. Switch activation will cause the following:

- Placing the switch in the UP or Manual Evacuate latching position will generate the programmed evacuation tones/messages out of the amplifiers. Returning the switch to the normal position will stop the audio output.
- Holding the switch in the Down or Message Override non-latching position interrupts the generated audio output from the amplifiers if the unit is in alarm. This allows use of the microphone for emergency paging. It is not necessary to hold the switch down when paging while the system is in the standby (nonalarm) state. Releasing the switch while in alarm, returns the VECP to generating audio evacuation tone(s)/messages(s).

FIGURE 4-1:Front Panel

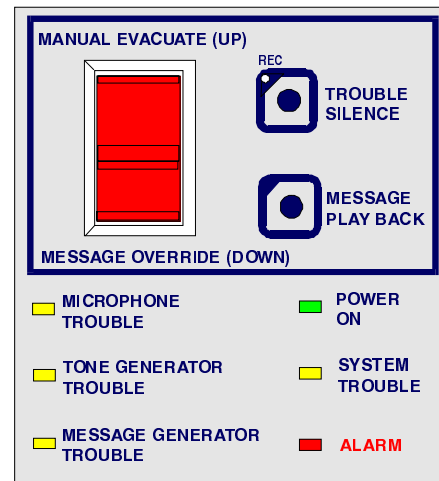

4.1.2 REC - Record Push Button

The switch labeled TROUBLE SILENCE is also used for recording a customized message. The switch is not labeled as 'record' to help prevent unauthorized recording.

Recording Instructions

Recording a custom message or messages into the VECP requires that the voice message(s) be input via the internal microphone or via the RCA Jack.

1. Select whether a single 60 second message or two 30 second messages will be recorded by setting S5 switch 2 to the OFF position for one 60 second message or to the ON position for two 30 second messages.
2. Enable recording by setting S5 switch 8 to the ON position. The Trouble Silence key is now ready to be used in record operation.
3. Select the record input source by setting S5 switch 7 to the OFF position if recording via the microphone, or to the ON position if recording via the RCA Jack.
4. Slide the Record Bypass switch S2 to the UP position to enable the message storage device.
5. Note the following while recording:
 - ✓ To alert the user that there is only five seconds of record time remaining, the REC LED will change from steady-on to flashing
 - ✓ The system Trouble LED and Trouble Relay will be on while recording but the Trouble Sounder will remain off. The system will not respond to the CMD inputs or Manual Evacuate switch while recording
 - ✓ It is not necessary to fill the entire 60 second or 30 second record time. The time limits represent the maximum time allotted. For dual language recordings, it is recommended that the 60 second option be selected. The two 30 second recordings should only be used for fire/nonfire or fire-evacuation/fire-clear messages
 - ✓ Factory default messages are replaced with the custom messages recorded from the RCA jack or internal microphone

Recording one 60 second message from the RCA jack

1. Press the keypad switch labeled Trouble Silence to begin recording. The green REC LED, located in the upper left hand corner of the Trouble Silence key, will begin to flash at a one second rate.
2. After five seconds, the REC LED will turn on steady and recording of the custom message may now commence.
3. Upon completion of the custom recording, press the Trouble Silence key to terminate the process. The REC LED will extinguish.

Recording two 30 second messages from the RCA jack

1. Press the keypad switch labeled Trouble Silence to begin recording. The green REC LED, located in the upper left hand corner of the Trouble Silence key, will begin to flash at a one second rate.
2. After five seconds, the REC LED will turn on steady and recording of the first custom message may now commence.
3. Upon completion of the custom recording, press the Trouble Silence key to terminate the record process for the first message. The REC LED will now flash at a ½ second rate for five seconds, to prompt for the recording of the second message.
4. After this period, the REC LED will turn on steady and recording of the second custom message may now commence.
5. Upon completion of the custom recording, press the Trouble Silence key to terminate the recording of the second message. The REC LED will extinguish.

Recording only the first 30 second message from the RCA jack

1. Press the keypad switch labeled Trouble Silence to begin recording. The green REC LED, located in the upper left hand corner of the Trouble Silence key, will begin to flash at a one second rate.
2. After five seconds, the REC LED will turn on steady and recording of the first custom message may now commence.
3. Upon completion of the custom recording, press the Trouble Silence key to terminate the recording of the first message.
4. The REC LED will now flash at a ½ second rate for five seconds. During that time, press the Trouble Silence key to terminate the record process. *The Trouble Silence key must be pressed within this five second time frame or accidental erasure of the second message will occur.*

Recording only the second 30 second message from the RCA jack

1. Press the keypad switch labeled Trouble Silence to begin recording. The green REC LED, located in the upper left hand corner of the Trouble Silence key, will begin to flash at a one second rate.
2. While the LED is flashing, press the Trouble Silence key again to advance to the beginning of the second message. *The Trouble Silence key must be pressed within five seconds or accidental erasure of the first message will occur.* The REC LED will now flash at a ½ second rate for five seconds to prompt for the recording of the second message.
3. After five seconds, the REC LED will turn on steady and recording of the second custom message may now commence.
4. Upon completion of the custom recording, press the Trouble Silence key to terminate the recording of the second message. The REC LED will extinguish.

Recording one 60 second message from the microphone

1. Press the keypad switch labeled Trouble Silence to begin recording. The green REC LED, located in the upper left hand corner of the Trouble Silence key, will begin to flash at a one second rate.
2. Within five seconds, press the microphone push-to-talk switch. The REC LED will turn on steady. Speak into the microphone to record the custom message.
3. To terminate the record process, press the Trouble Silence key or release the microphone push-to-talk switch. The REC LED will extinguish.

Recording two 30 second messages from the microphone

1. Press the keypad switch labeled Trouble Silence to begin recording. The green REC LED, located in the upper left hand corner of the Trouble Silence key, will begin to flash at a one second rate.
2. Within five seconds, press the microphone push-to-talk switch. The REC LED will turn on steady. Speak into the microphone to record the first custom message.
3. Release the microphone push-to-talk switch to end recording the first message. The REC LED will now flash at a ½ second rate to prompt for the recording of the second message.
4. Within five seconds, press the microphone push-to-talk switch. The REC LED will turn on steady. Speak into the microphone to record the second custom message.
5. To terminate the record process, press the Trouble Silence key or release the microphone switch. The REC LED will extinguish.

Recording only the first 30 second message from the microphone

1. Press the keypad switch labeled Trouble Silence to begin recording. The green REC LED, located in the upper left hand corner of the Trouble Silence key, will begin to flash at a one second rate.
2. Within five seconds, press the microphone push-to-talk switch. The REC LED will turn on steady. Speak into the microphone to record the first custom message.
3. Upon completion of the custom recording, release the microphone push-to-talk switch to terminate the recording of the first message.
4. The REC LED will now flash at a ½ second rate to prompt for the recording of the second message. During that time, press the Trouble Silence key to terminate the record process.

Recording only the second 30 second message from the microphone

1. Press the keypad switch labeled Trouble Silence to begin recording. The green REC LED, located in the upper left hand corner of the Trouble Silence key, will begin to flash at a one second rate.
2. While the LED is flashing, press the Trouble Silence key a second time to advance to the beginning of the second message. The REC LED will now flash at a ½ second rate to prompt for the recording of the second message.
3. Within 5 seconds, press the microphone push-to-talk switch. The REC LED will turn on steady. Speak into the microphone to record the second custom message.
4. To terminate the record process, press the Trouble Silence key or release the microphone push-to-talk switch. The REC LED will extinguish.



CAUTION! *Be certain to slide the Record Bypass switch S2 to the Down position when recording is completed. This will prevent accidental rerecording or deletion of the stored message(s). It is not possible to record with the S2 Record Bypass switch in the Down position.*

4.1.3 Playback Button

The Playback button can be used to review the stored voice message(s). By connecting the optional Local Playback Speaker Module, the message can be heard without transmitting it over the system speakers. Pressing the Playback button will cause the following:

- In a system set for one 60 second message, the message will play until the end or until the Playback button is pressed a second time.
- In a system set for two 30 second messages, the first message will play until the end or until the Playback button is pressed a second time, which will start the second message. The second message will play until the end or until the Playback button is pressed to stop the message.

Note that the voice message will repeat according to the S1 DIP switch settings (see 2.1“S1 DIP Switch Settings” on page 15). Refer to Figure 3-18, “Installation of Speaker Module,” on page 31, for additional information.

4.2 LED Indicators

4.2.1 LEDs Visible with Backbox Door Closed (Refer to Figure 4-1 on page 32)

Power On

A green LED that remains on while the DC power source is within correct limits. *If this indicator fails to light under normal conditions, service the system immediately.*

System Trouble

This yellow LED turns on steady to indicate that a fault or abnormal condition exists and that the VECP may be inoperative.

Alarm

A red LED that turns on steady when either CMD1 or CMD2 inputs are triggered. The LED also turns on when the Manual Evacuation switch is in the latched position.

Microphone Trouble

This yellow LED turns on steady when the supervised microphone connection is open.

Tone Generator Trouble

This yellow LED turns on steady when one of the supervised tone generators fail or fall below acceptable levels.

Message Generator Trouble

This yellow LED turns on steady when the supervised digital message generator fails or falls below acceptable levels.

REC (Record) - Located on Front Panel Trouble Silence Button

This green LED pulses once every second when ready to record one 60 second message or twice every second when ready to record two 30 second messages. It turns on steady while recording and then pulses when five seconds of recording time remains. The LED shuts off when recording time has terminated.

4.2.2 LEDs Visible with Door Open and Optional Dress Panel Removed (Figure 1-1 & Figure 1-2)

AMP SUPR - Supervision (Audio Amplifier Module)

This green LED (one on each amplifier), when on steady, indicates that the amplifier is fully functional. The VECP constantly tests the amplifier to verify proper operation.

Circuit Trouble (Audio Amplifier Module)

This yellow LED (one on each amplifier) turns on steady when a trouble is detected in the amplifier or to indicate an open or short circuit on the field wiring attached to the amplifier output terminals.

Ground Fault (Power Supply/Battery Charger Module)

This yellow LED turns on steady when a ground fault condition is detected on the system.

Battery Trouble (Power Supply/Battery Charger Module)

This yellow LED turns on steady when the battery is disconnected or battery voltage drops below an acceptable level.

AC ON (Power Supply/Battery Charger Module)

This green LED remains on while AC power is within correct limits. *If this indicator fails to light under normal conditions, service the system immediately).*

4.3 Operation

The VECP continuously monitors system status. When no system alarm or local trouble conditions exist, all LEDs are off except the Power On LED located on the front panel keypad, the amplifier supervision LED(s) and the AC ON LED located on the optional Power Supply/Battery Charger Module. The Notification Appliance Circuits (speakers) are off and all relays are in their normal state. Alarm and local troubles are announced by the VECP's LEDs.

4.3.1 Fire Alarm

The Voice Evacuation Control Panel will, upon detection of an alarm condition (either CMD1 or CMD2 Inputs):

- ✓ Turn on the front panel Alarm LED steady
- ✓ Activate (reverse polarity) Master Command Output Bus
- ✓ Turn on the appropriate Notification Appliance Circuit speakers (depending on CMD input source)
- ✓ Turn on the appropriate Audio Amplifier
- ✓ Transmit the tone before message if programmed (repeating tone number of times programmed)
- ✓ Transmit the appropriate (CMD2 can be programmed to transmit secondary 'nonfire' message) digital voice message (repeating message number of times programmed)
- ✓ Transmit the tone after message if programmed (repeating tone number of times programmed)
- ✓ Transmit a primary evacuation tone only (if programmed)

4.3.2 Fire Alarm Restoral

- ✓ Turn off the Alarm LED located on the front panel
- ✓ Deactivate the Master Command Bus
- ✓ Turn off the Notification Appliance Circuits
- ✓ Turn off the Audio Amplifiers
- ✓ Turn off the digital voice message or tone at its present point in transmission

4.3.3 Manual Evacuation Switch Activation

The Voice Evacuation Control Panel will, upon activation of the Manual Evacuation switch:

- ✓ Turn on the panel Alarm LED steady
- ✓ Activate (reverse polarity) Master Command Bus
- ✓ Turn on all Notification Appliance Circuit speakers
- ✓ Turn on the Audio Amplifiers
- ✓ Transmit the tone before message if programmed
- ✓ Transmit the appropriate digital voice message (repeating message the number of times programmed)
- ✓ Transmit the tone after message if programmed (repeating tone the number of times programmed)
- ✓ Transmit a primary evacuation tone only if programmed (repeating tone the number of times programmed)

4.3.4 Manual Evacuation Switch Restoral

The Voice Evacuation Control Panel will, upon return of Manual Evacuation switch to normal position:

- ✓ Turn off the panel Alarm LED
- ✓ Deactivate (return to normal) Master Command Output Bus
- ✓ Turn off all Notification Appliance Circuit speakers
- ✓ Turn off the Audio Amplifiers
- ✓ Turn off the digital voice message or tone at its present point in transmission

4.3.5 Message Override Switch

The Message Override switch is a momentary switch which interrupts the selected evacuation tone and/or message. While the unit is in alarm, holding the Message Override switch down shuts off the recorded message(s) or tones but leaves the amplifiers on. Pressing the microphone key allows manual emergency voice messages to override the built-in message(s). Releasing both the microphone key and the Manual Override switch causes the VECP to return to generating the recorded message(s) and/or tones.

4.3.6 Trouble Condition Response

All trouble conditions will cause the following to occur (Note: All trouble conditions fully supervised in standby and alarm unless otherwise noted):

- ✓ Deactivate the trouble relay
- ✓ Turn on local piezo
- ✓ Turn on the system Trouble LED
- ✓ Open CMD1 input - ONLY if CMD1 is not in the alarm state

In addition to the above trouble responses, the following troubles will cause the specific responses noted:

AC Loss

- Turn off the AC ON LED on the FC-PSM(E) module
- The Power On LED on the front panel remains on if battery power is supplied
- Deactivate the AC Loss Relay on the FC-PSM(E) (immediate or 6 hour delay depending on S1 position)

Battery Trouble (low or no battery)

- Turn on the Battery Trouble LED on the FC-PSM(E) module

Ground Fault

- Turn on the Ground Fault LED on the FC-PSM(E) module

Microphone Fault

- Turn on the Microphone Trouble LED on the front panel

Tone Generator Fault

- Turn on the Tone Generator Trouble LED on the front panel

Message Generator Trouble

- Turn on the Message Generator Trouble LED on the front panel

CMD1 or CMD2

- Both inputs are supervised for open circuit condition when unit is programmed for Normally Open contacts, otherwise supervision is provided by the host Fire Alarm Control Panel NAC output

Master Command

- Polarity reversal circuit supervised for open and short circuits while in standby only.

Background Music

- When background music option is enabled via DIP switch S5 switch 3, the VECP will constantly monitor the external audio input RCA Jack. A fault condition will occur when the audio level input falls below acceptable limits for 75 seconds. Both amplifiers and speaker wiring continue to be fully supervised* when background music is output from the VECP. Note that when AC power is lost, the VECP will shut off background music to conserve batteries. Background music requires installation of the FC-PSM(E) module. (Not UL approved for use when the VECP is powered via TB3).

**Note that when the 70.7 V_{RMS} Transformer Module is installed, the use of background music is not permitted.*

Amplifier Fault

- Both amplifiers are constantly monitored for proper functionality. Should either amplifier fail, the AMP SUPR LED will turn off and the circuit Trouble LED will turn on. When the system is configured for backup, failure of the primary amplifier will cause the backup amplifier to be switched in.

NAC (Speaker) Output

- The wiring to each amplifier is supervised for opens and shorts at all times in standby and while in alarm or when background music is enabled*. A wiring fault will cause the circuit Trouble LED located on each amplifier module to turn on. It should be noted that the green AMP SUPR LED may remain on for wiring faults.

**Note that when the 70.7 VRMS Transformer Module is installed, the use of background music is not permitted.*

Power LED

- When external power is used to power the VECP [FC-PSM(E) module not installed], a loss of input power at TB3 will turn off the Power On LED.

Internal Power Supplies

- Power fed to the amplifiers from the main circuit board is fully supervised. Should standby or alarm power feeds to either amplifier fail, the unit will go into trouble.

Note that a power trouble on one amplifier will not affect the power to the other amplifier.

4.3.7 Trouble Condition Restoral

All trouble condition restorals will cause the following to occur:

- ✓ Reactivate the trouble relay
- ✓ Turn off local piezo
- ✓ Turn off the system Trouble LED
- ✓ Close CMD1 input

In addition to the above trouble condition restorals, the following specific restorals will occur:

AC restoral

- Turn on the AC ON LED on the FC-PSM(E) module
- The Power On LED on the front panel remains on
- Reactivate the AC Loss Relay on the FC-PSM(E)

Battery restoral

- Turn off the Battery Trouble LED on the FC-PSM(E) module

Ground Fault cleared

- Turn off the Ground Fault LED on the FC-PSM(E) module

Microphone restoral

- Turn off the Microphone Trouble LED on the front panel

Tone Generator restoral

- Turn off the Tone Generator Trouble LED on the front panel

Message Generator restoral

- Turn off the Message Generator Trouble LED on the front panel

Amplifier restoral

- The AMP SUPR LED will turn on and the circuit Trouble LED will turn off. When the system is configured for backup, restoral of the primary amplifier will cause the backup amplifier to be switched out

NAC (Speaker) Output restoral

- The wiring to each amplifier is supervised for opens and shorts at all times in standby and while in alarm or when background music is enabled*. A restoral of a wiring fault will cause the circuit Trouble LED located on each amplifier module to turn off. It should be noted that the green AMP SUPR LED is on

**Note that when the 70.7 V_{RMS} Transformer Module is installed, the speaker wiring is not supervised while in alarm and the use of background music is not permitted.*

Power LED - power restoral

- When external power is used to power the VECP [FC-PSM(E) module not installed], a restoral of input power at TB3 will turn on the Power On LED

Internal Power Supplies restoral

- Power fed to the amplifiers from the main circuit board is fully supervised. Restoral of standby or alarm power feeds to either amplifier will cause the unit to clear the trouble indications

CHAPTER 5 *Application Examples*

The FIRE•COMMAND•25/50 is a Voice Evacuation Control Panel which can be used, with a variety of Fire Alarm Control Panels, to provide emergency audio messages. This chapter contains a few application examples and is not meant to provide a comprehensive list of all possible VECP applications.

5.1 One Speaker Circuit

A very basic application consists of one FIRE•COMMAND•25/50 with one amplifier and a single speaker circuit. This configuration is suitable for small facilities requiring no more than 25 watts of output power. A single fire evacuation message will be generated during an alarm condition from the host FACP or activation of the Manual Evacuate switch.

In this application, the NAC from the host FACP is connected to CMD1. The CMD1 out terminals are then terminated with an EOL resistor for the FACP's Style Y NAC or the terminals are wired back to the host FACP for a Style Z NAC. S5 DIP switch 2 is set to OFF which causes the speaker circuit to be activated by the CMD1 input. S5 DIP switch 5 is set to OFF which causes CMD1 input to be activated by a reverse polarity condition.

FIGURE 5-1: One 25 Watt Speaker Circuit

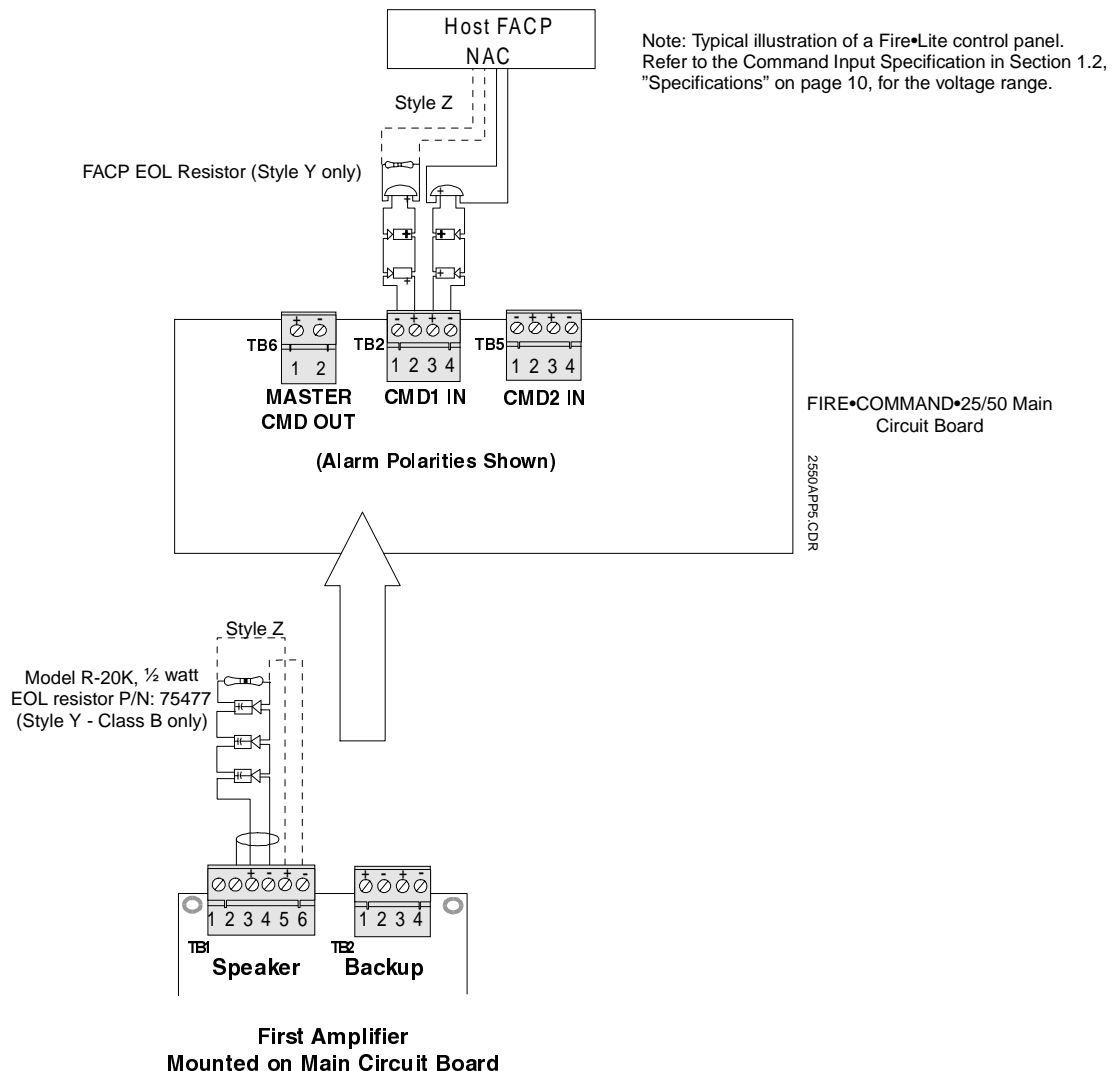

5.2 One Speaker Circuit With Backup

Another application consists of one FIRE•COMMAND•25/50 with one amplifier and a single speaker circuit. A second amplifier can be installed as a backup if desired. This configuration is suitable for small facilities requiring no more than 25 watts of output power. A single 60 second fire evacuation message will be generated during an alarm condition from the host FACP or activation of the Manual Evacuate switch.

In this application, the NAC from the host FACP is connected to CMD1. The CMD1 out terminals are then terminated with an EOL resistor for the FACP's Style Y NAC or the terminals are wired back to the host FACP for a Style Z NAC. S5 DIP switch 2 is set to OFF which causes the speaker circuit to be activated by the CMD1 input. S5 DIP switch 5 is set to OFF which causes CMD1 input to be activated by a reverse polarity condition.

Backup Amplifier switch S1 is set to the 'Backup ON' position. 18 AWG or larger jumpers connect the Backup Amplifier TB2 Terminal 3 and Main Amplifier TB2 Terminal 2 as well as Backup Amplifier TB2 Terminal 4 and Main Amplifier TB2 Terminal 1. Upon failure of the first or main amplifier, the audio from the backup amplifier will be switched out to the speakers.

Note that in the optional 70.7 VRMS configuration, only the amplifier is backed-up; the FC-XRM70 coupling transformer is not. For this reason, it is not necessary to install an FC-XRM70 transformer module on the backup amplifier.

FIGURE 5-2: One 25 Watt Speaker Circuit With Backup

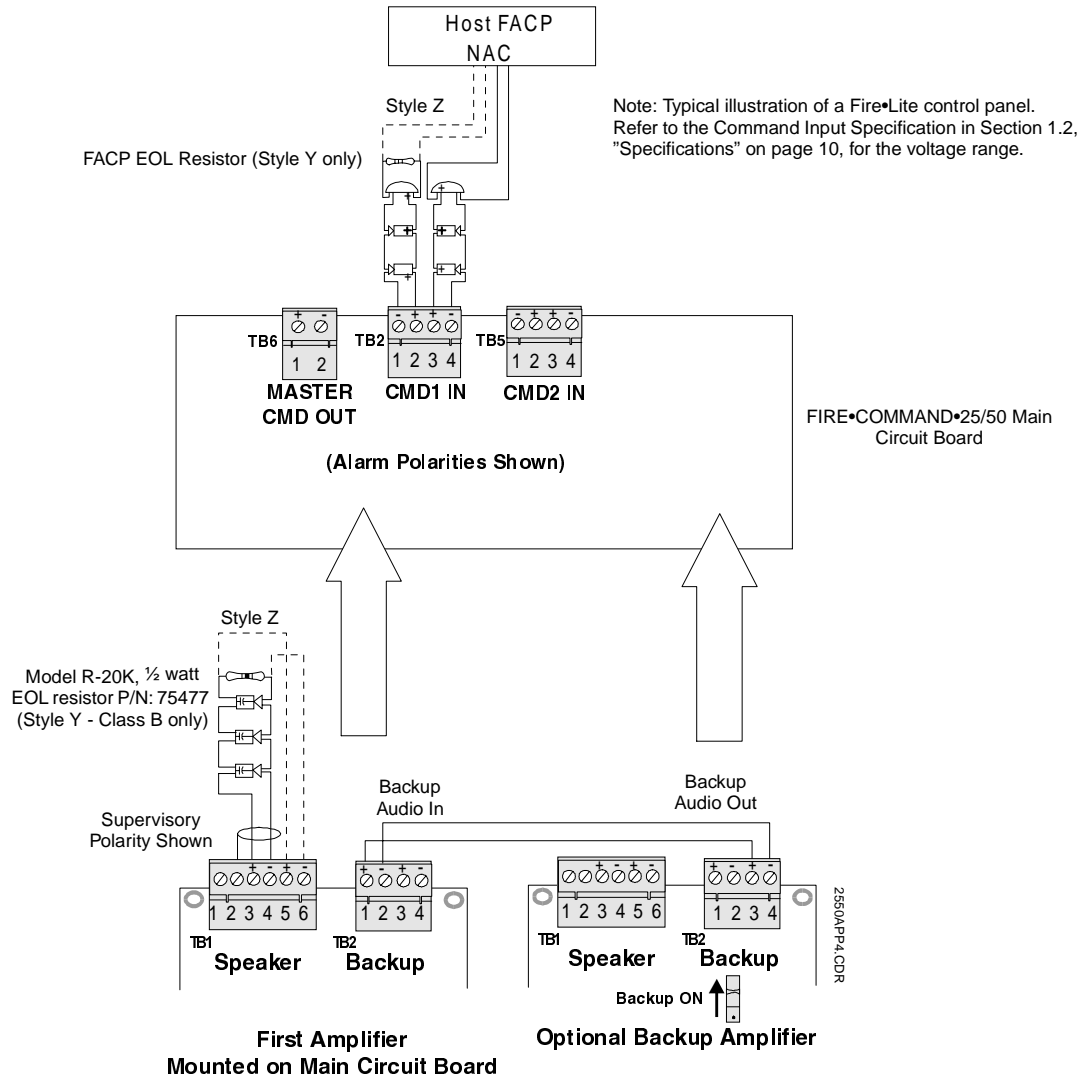

5.3 Two Speaker Circuits - One 60 Second Message On Both Amps

This application consists of one FIRE•COMMAND•25/50 with two speaker circuits which requires installation of the optional second amplifier. This configuration is suitable for small facilities requiring no more than 50 watts of output power. A 60 second fire evacuation message will be generated over both speaker circuits simultaneously during an alarm condition from the host FACP or when the Manual Evacuate switch is activated.

In this application, the one NAC from the host FACP is connected to CMD1 In terminals. The CMD1 Out terminals are then jumpered to the CMD2 In terminals. The CMD2 Out terminals may then be terminated with an EOL resistor for the FACP's Style Y NAC or the terminals may be wired back to the host FACP for a Style Z NAC. Note that additional NAC devices may be connected to the CMD2 Out terminals as illustrated in Figure 5-3.

S5 DIP switch 2 is set to OFF which causes transmission of the primary 'fire' message over speaker circuits 1 and 2 upon activation of CMD1 and CMD2. S5 DIP switch 5 is set to OFF which causes CMD1 input to be activated by a reverse polarity condition and S5 DIP switch 6 is set to OFF which also causes CMD2 input to be activated by a reverse polarity condition.

FIGURE 5-3:Two Speaker Circuits - One 60 Second Message On Both Amps

Note: Typical illustration of a Fire•Lite control panel. Refer to the Command Input Specification in Section 1.2, "Specifications" on page 10, for the voltage range.

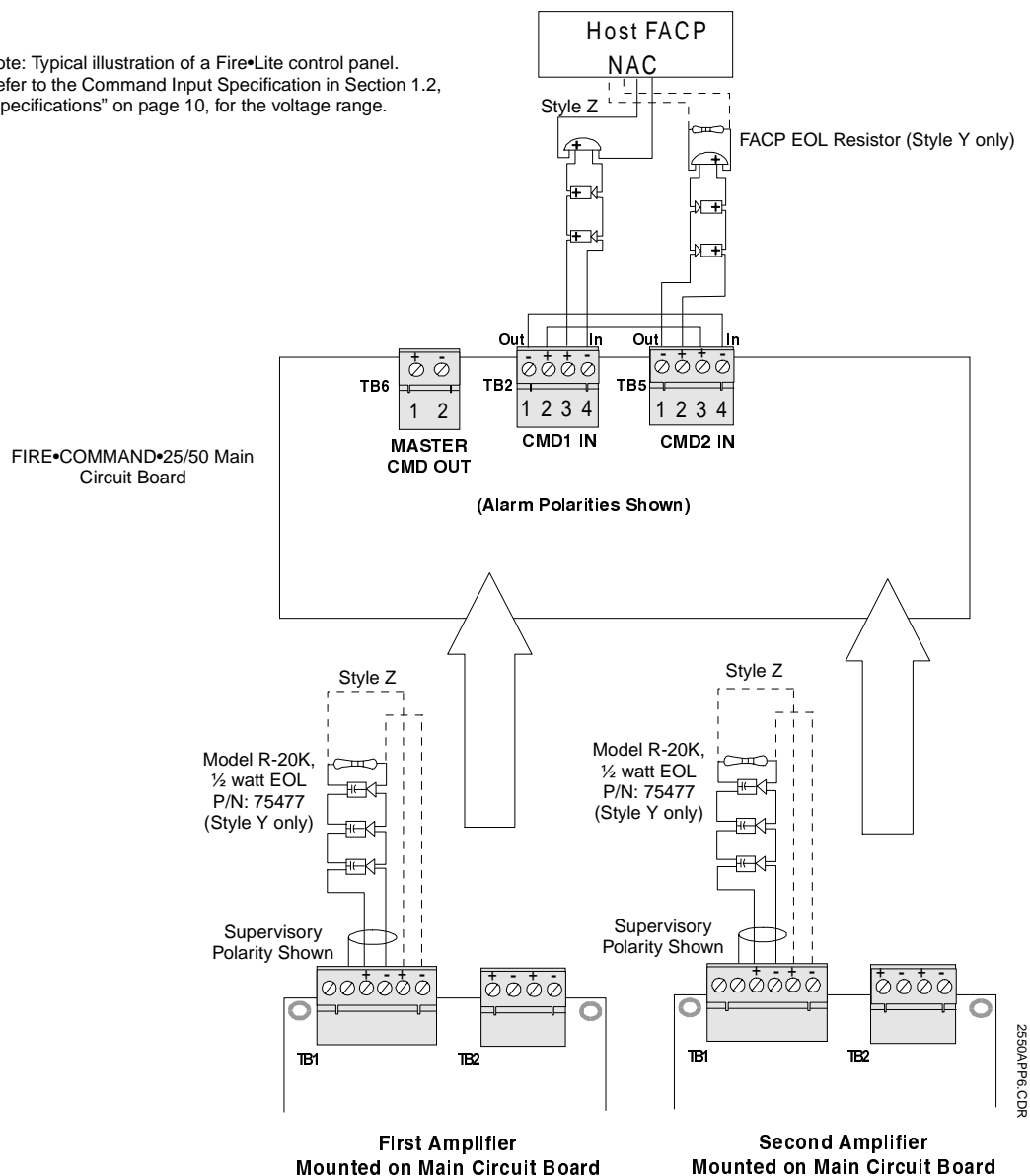

5.4 Two Speaker Circuits - Two 30 Sec. Messages (Fire and Nonfire)

This application consists of one FIRE•COMMAND•25/50 with two speaker circuits which requires installation of the optional second amplifier. This configuration is suitable for small facilities requiring no more than 50 watts of total output power (provided on dual 25 watt speaker circuits). A fire evacuation message will be generated over both speaker circuits during an alarm condition from the host FACP and an emergency 'nonfire' message can be manually generated over both circuits.

In this application, one NAC from the host FACP is connected to the CMD1 In terminals. The CMD1 Out terminals are then terminated with an EOL resistor for the FACP's Style Y NAC or the terminals are wired back to the host FACP for a Style Z NAC. CMD2 is connected to a normally open contact which can be used to manually generate an emergency 'nonfire' message (i.e. tornado warning).

S5 DIP switch 2 is set to ON which causes transmission of the primary 'fire' message over speaker circuits 1 and 2 upon activation of CMD1 and transmission of the secondary 'nonfire' message over speaker circuits 1 and 2 upon activation of CMD2. S5 DIP switch 5 is set to OFF which causes CMD1 input to be activated by a reverse polarity condition and S5 DIP switch 6 is set to ON which causes CMD2 input to be activated by a contact closure.

FIGURE 5-4: Two Speaker Circuits - Two Messages

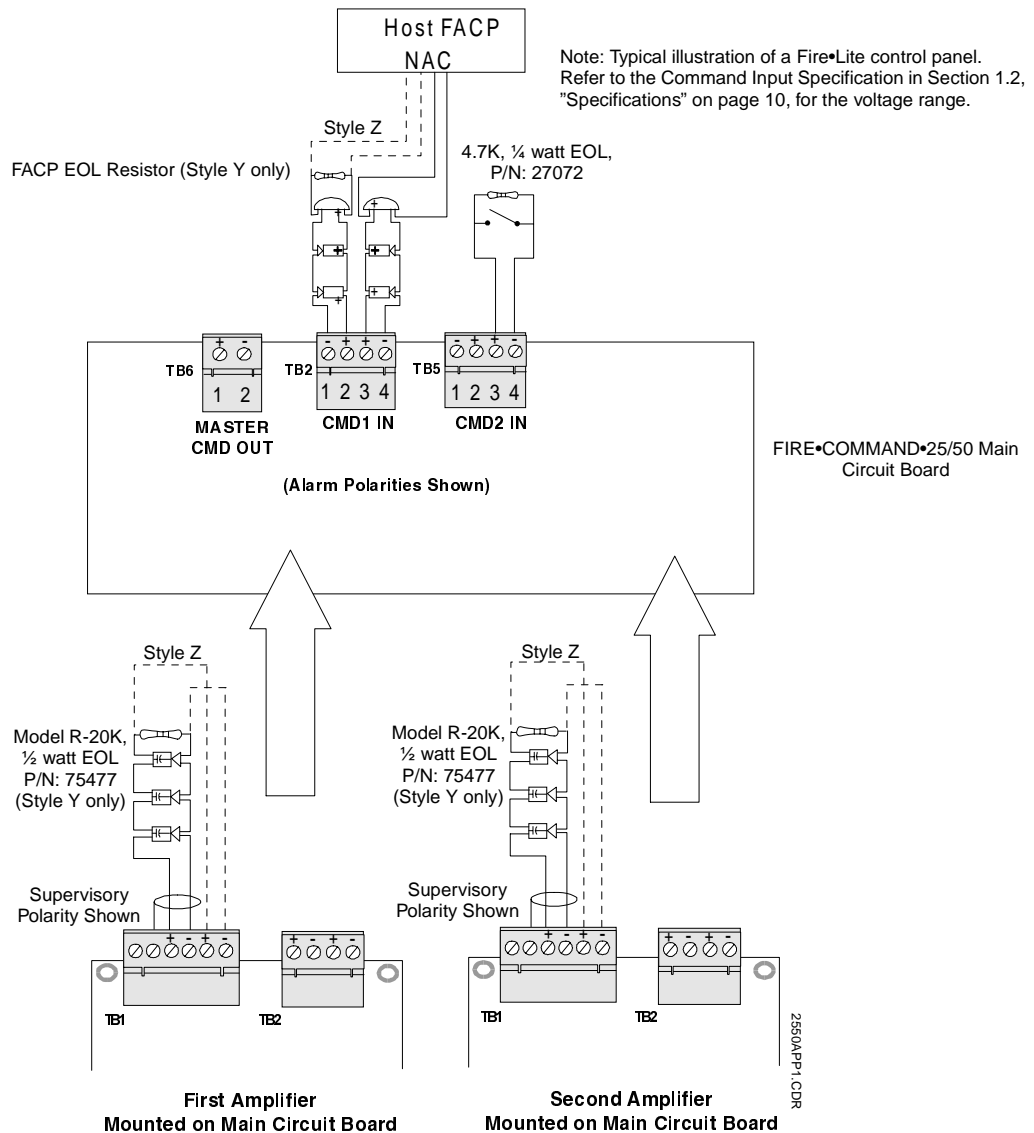

5.5 Two Speaker Circuits - One or Two Messages (CMD1 and CMD2 Amp Selection)

This application consists of one FIRE•COMMAND•25/50 with two speaker circuits which requires installation of the optional second amplifier. This configuration is suitable for small facilities requiring no more than 50 watts of output power. Depending on configuration switch settings and activation of one of the Command CMD inputs, a fire evacuation message can be generated over one or both speaker circuits or one of two different messages can be generated over both circuits.

In this application, one NAC from the host FACP is connected to CMD1. The CMD1 Out terminals are then terminated with an EOL resistor for the FACP's Style Y NAC or the terminals are wired back to the host FACP for a Style Z NAC. A second NAC from the host FACP is connected to CMD2. The CMD2 Out terminals are then terminated with an EOL resistor for the FACP's Style Y NAC or the terminals are wired back to the host FACP for a Style Z NAC.

S5 DIP switch 2 set to OFF causes transmission of one 60 second message. Activation of one or both CMD inputs determine which amplifier is on. S5 DIP switch 2 set to ON causes transmission of two 30 second messages. Control of which message to be played over both amplifiers is via CMD1 and CMD2 (refer to charts in Section 2.2). S5 DIP switches 5 and 6 are set to OFF which causes CMD1 and CMD2 inputs to be activated by reverse polarity conditions.

FIGURE 5-5: Two Speaker Circuits - One of Two Messages

Note: Typical illustration of a Fire•Lite control panel. Refer to the Command Input Specification in Section 1.2, "Specifications" on page 10, for the voltage range.

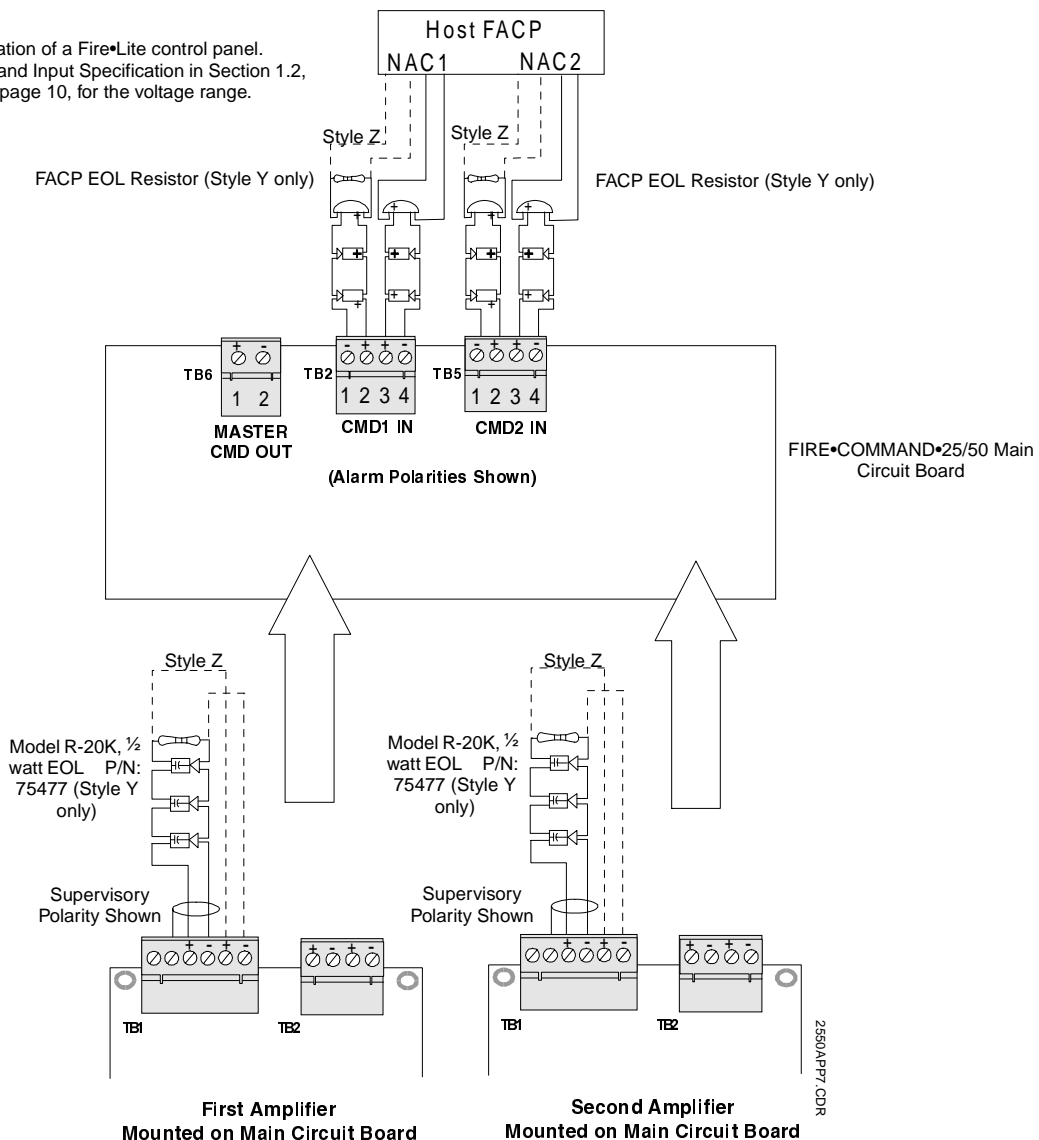

Appendix A *Battery Calculations*

When the optional FC-PSM(E) Power Supply/Battery Charger is installed, use the Total Standby and Alarm Load Currents calculated in Table A-2 and Table A-3 for the following battery calculation. When powered by an external power source via TB3, use Table A-2 and Table A-3 to assist in the battery calculations.

TABLE A-1: Battery Calculations

Standby Load Current in amps (from Table A-2)	X	Required Standby Time in Hours (24 or 60 Hours)	=	
[]		[]		
Alarm Load Current in amps (from Table A-3)	X	Required Alarm Time in Hours (i.e. 15 min. = 0.250 Hours) ¹	=	
[]		[]		
Add Standby and Alarm Load for Required Ampere Hour Battery				
Multiplying by derating factor of 1.2				X 1.2
Total Ampere Hour Battery ^{2, 3}				

1. NFPA requires a minimum of 15 minutes of alarm time and 24 hours standby time for voice message systems. Consult Local Authority Having Jurisdiction for local requirements.
2. 7 Ampere Hour battery can be located in the FIRE•COMMAND•25/50 backbox.
3. Greater than 7 Ampere Hour up to 17 Ampere Hour battery requires the BB-17F battery box.

Enter the total standby current requirements into Table A-2 for the FIRE•COMMAND•25/50. When the optional FC-PSM(E) Power Supply/Battery Charger is installed, enter total standby current requirements calculated in Table A-2 into Table A-1. If power is being provided by regulated 24 VDC from a separate power supply such as the FCPS-24F(E) or an FACP, use the standby current calculated in Table A-2 to calculate battery requirements for the separate power supply or FACP.

TABLE A-2: Regulated Load in Standby

Device Type	# of Devices		Current (amps)		Total Current (amps)
Main circuit board and one Audio Amplifier	(1 maximum)	X	0.180	=	0.180
FC-PSM(E)	(1 maximum)	X	0.030	=	
Optional Audio Amplifier ^{1, 2} (FC-AAM25)	(1 maximum)	X	0.030	=	
Additional Draw from TB4 Aux Power (0.035 amps maximum)			[]	=	
Sum Column for Standby Load				=	amps

1. The FC-XRM70 Transformer Module draws no current in standby.
2. The FC-LPS Local Playback Speaker Module draws no current in standby.

Battery Calculations

Enter the total alarm current requirements into Table A-3 for the FIRE•COMMAND•25/50. When the optional FC-PSM(E) Power Supply/Battery Charger is installed, enter the total alarm current requirements calculated in Table A-3 into Table A-1 and perform calculations. If power is being provided by a regulated 24 VDC from a separate power supply such as the FCPS-24F(E) or an FACP, use the alarm current calculated in Table A-3 to calculate battery requirements for the separate power supply or FACP.

TABLE A-3: Regulated Load in Alarm

Device Type	# of Devices		Current (amps)	=	Total Current (amps)
Main Circuit Board	(1 maximum)	X	0.180	=	0.180
FC-PSM(E)	(1 maximum)	X	0.030	=	
First Audio Amplifier ¹ (FC-AAM25)	(1 standard)	X	1.0	=	1.0
Optional Audio Amplifier ¹ (FC-AAM25)	(1 maximum)	X	1.0	=	
Additional Draw from TB4 Aux. Power (0.035 amps maximum)			[]	=	
Sum Column for Alarm Load				=	amps

1. Maximum alarm current is 1.0 amp per amplifier (1.0 amp = 25 watts)

Note:

- The FC- XRM70 Transformer Module draws no current in standby.
- The FC-LPS Local Playback Speaker Module draws no current in standby.
- The FIRE•COMMAND•25/50 will shut off background music in the event AC power is lost in order to conserve battery power. Background music may be selected only when the optional FC-PSM(E) module is installed (requires approval of Local AHJ).

Appendix B *Digital Voice Messages*

The FIRE•COMMAND•25/50 digital message generator provides a 60 second record time which allows for a single fire message of 60 seconds length or two 30 second messages. One or two messages may be field programmed. Refer to 4.1.2“REC - Record Push Button” on page 32. The FIRE•COMMAND•25/50 is provided with a factory recorded single ‘primary’ message which can be changed in the field. The prerecorded message (female voice) is:

“May I have your attention please. May I have your attention please. The signal you have just heard indicates a report of a fire in this building. Please proceed to the nearest exit and leave the building. Do not reenter the building unless directed to do so by the proper authorities.”

New ‘primary’ and ‘secondary’ messages can be recorded in the field. Be certain to get the approval of the Local Authority Having Jurisdiction prior to recording new messages. Following are some examples of ‘primary’ and ‘secondary’ messages which may be recorded in the field:

- “May I have your attention please. May I have your attention please. There has been a fire reported on your floor. There has been a fire reported on your floor. Please proceed to the stairways and exit the building. Do not use the elevators.”
- “May I have your attention please. May I have your attention please. There has been a fire alarm reported in the building. There has been a fire alarm reported in the building. Please proceed to the stairways and exit the building. Do not use the elevators, but proceed to the stairways and exit the building.”
- “May I have your attention please. May I have your attention please. A tornado warning has been issued for this area. A tornado warning has been issued for this area. Please take all appropriate safety actions at this time.”
- “May I have your attention please. May I have your attention please. A hurricane warning has been issued for this area. A hurricane warning has been issued for this area. Please take all appropriate safety actions at this time.”
- “May I have your attention please. May I have your attention please. An emergency condition exists on this floor. An emergency condition exists on this floor. Please proceed to the stairways and exit the building. Do not use the elevators.”
- “May I have your attention. This is an emergency. Please walk to the nearest exit and go to your assembly areas and await further instructions. This is an emergency.”
- “Your attention please. The fire alarm in this building has been activated. Please cease operations immediately and proceed into the nearest fire exit. Descend to street level and leave the building. Do not use the elevator.”
- “There has been a Fire Emergency reported in this building. Proceed calmly to fire stairs. Do not use elevators. Do not contact the front desk unless evacuation assistance is required. Proceed directly to fire stairs. Fire personnel will assist disabled and elderly from the fire stairs. Floor Wardens report status by fire phone.”
- “May I have your attention please. There has been a Fire Emergency reported in the building. While this is being verified, please leave the building by the nearest exit or exit stairway.”
- “Attention. Your attention please. The building emergency condition has been cleared. You may return to your normal activities. The building emergency has been cleared. You may return to your normal activities.”
- “Your attention please. A severe weather warning has been received. Please walk to the nearest safe area and wait for further instructions. Elevator lobbies, stairwells, bathrooms and auditoriums are designated safe areas in the event of severe weather. Stay away from windows and glass. Do not use the elevators.”

Appendix C *FCPS-24F(E) Connections*

FIGURE C-1:FCPS-24F(E) Connections to FIRE•COMMAND•25/50

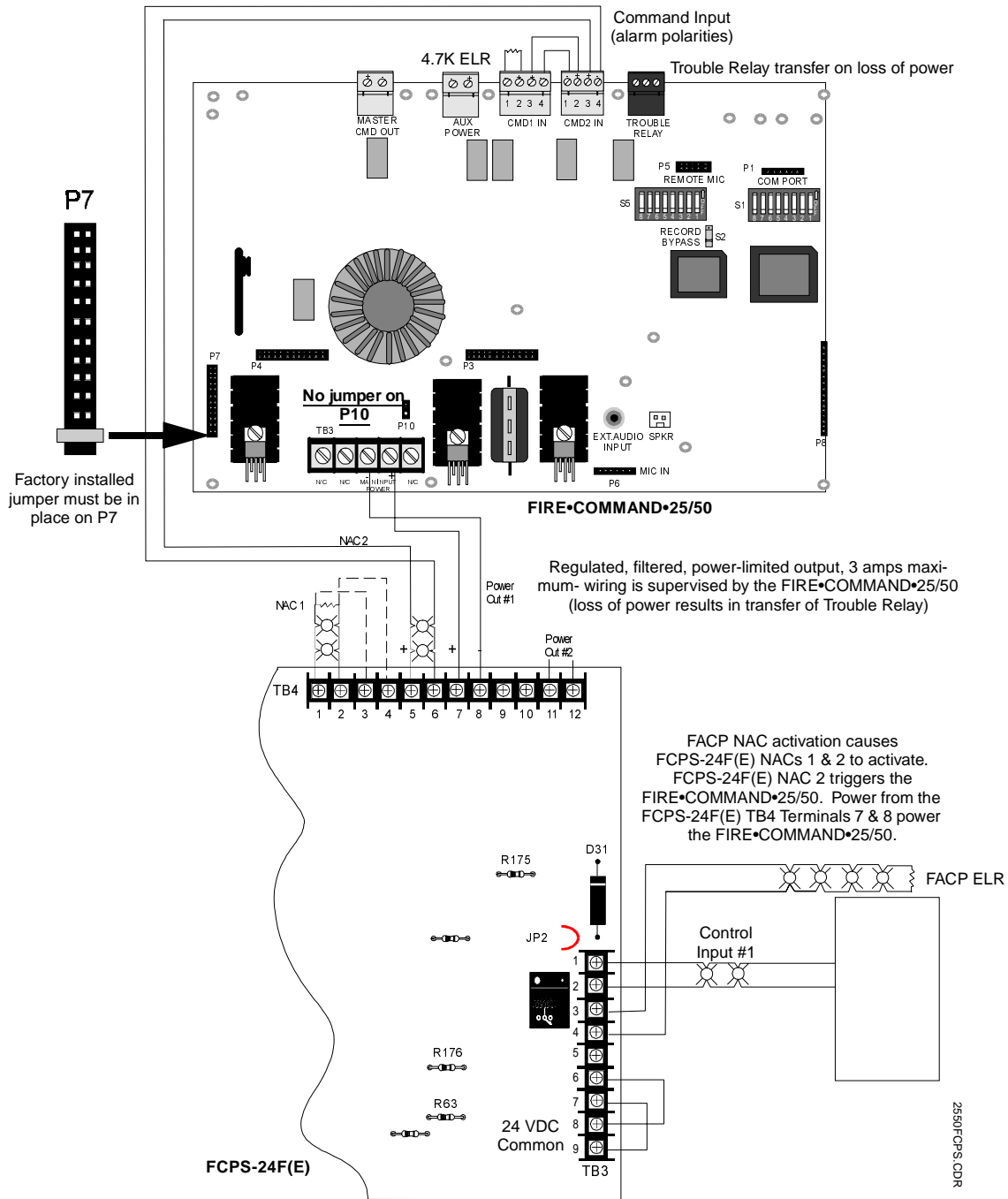

Notes:

- Maximum FIRE•COMMAND•25/50 amplifier output is 38 watts when two amplifiers are installed due to 3.0 amps current limitation of FCPS-24F(E) output (single amplifier panel will supply 25 watts).
- NAC 2 on the FCPS-24F(E), in addition to triggering the FIRE•COMMAND•25/50 by reverse polarity, can support notification appliances.
- On FIRE•COMMAND•25/50, do not jumper P10, but leave factory installed jumper in place on P7
- This configuration must not be used when background music is selected.

Appendix D

Addressable Module Connections

When configured with an addressable FACP such as the MS-9200(E), the FIRE•COMMAND•25/50 may be triggered either by the FACP main NAC output or from addressable control modules. Figure D-1 illustrates CMD1 triggered by an addressable control module. The addressable control module may trigger the FIRE•COMMAND•25/50 via reverse polarity (shown) or relay contact. The FACP monitors the FIRE•COMMAND•25/50 for faults while in the standby or alarm state by wiring a monitor module to the trouble contacts as shown in Figure D-1. Activation of the addressable control module is controlled by the FACP. Refer to the MS-9200(E) manual for additional information.

FIGURE D-1:Addressable Module Connections

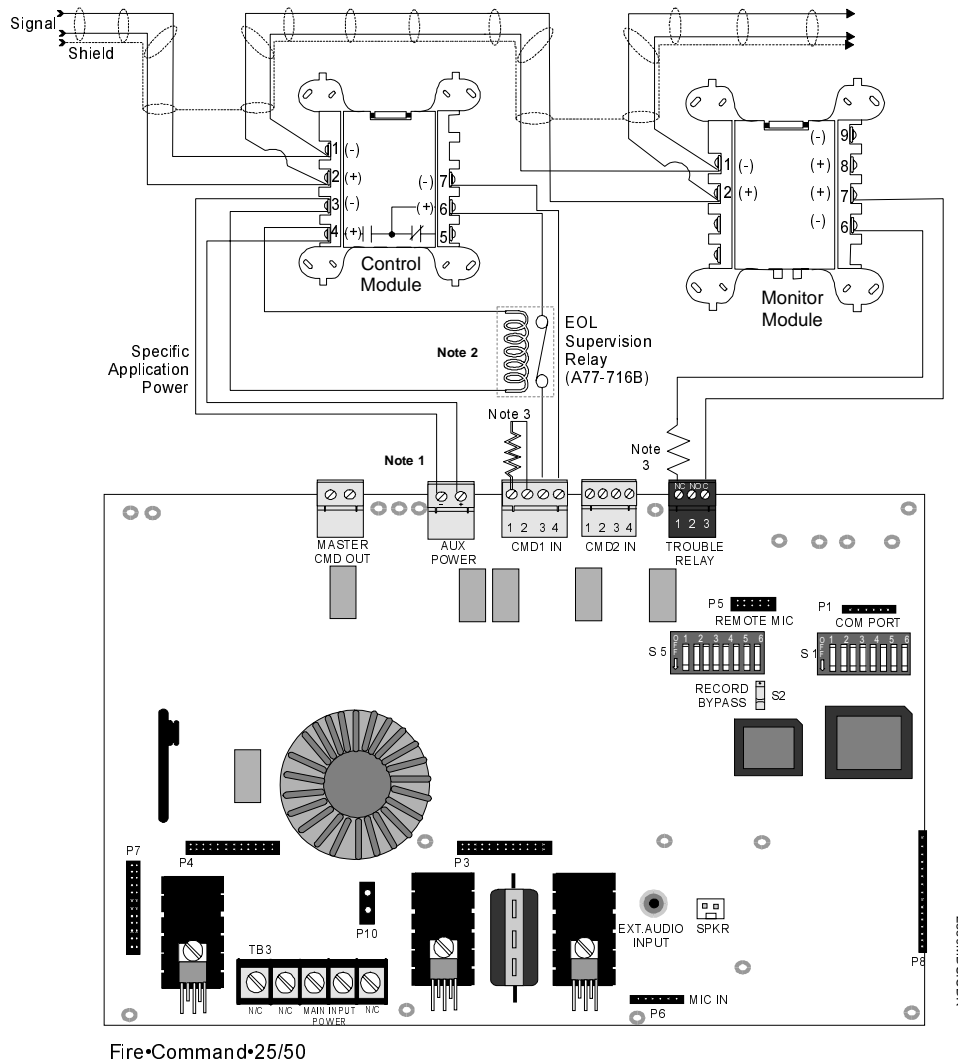

Notes:

1. Auxiliary Power terminals for special application power only. Wiring must remain in the room.
2. Supervise the wiring between the FIRE•COMMAND•25/50 Auxiliary Power output and the control module with an EOL relay (A77-716B)
3. EOL resistor supplied with modules.

Appendix E *Wiring Requirements*

Connecting external system accessories to the FIRE•COMMAND•25/50 main circuits must be carefully considered to ensure proper operation. It is important to use the correct type of wire, wire gauge and wire run length per each circuit. Refer to the following table to specify wire requirements and limitations.

NOTE: If an SLC loop is to be run in conduit with FIRE•COMMAND•25/50 Notification Appliance Circuits, the risk of encountering problems can be greatly reduced by using twisted, shielded cable on the SLC and NACs.

TABLE E-1: FIRE•COMMAND•25/50 Wiring Requirements

CIRCUIT CONNECTIONS		WIRE REQUIREMENTS		
Circuit Type	Circuit Function	Wire Type & Limitations	Recommended Maximum Distance (Feet)	Wire Gauge
AC Power FC-PSM(E) Module TB1 (nonpower-limited)	Primary Power Input to FC-PSM(E) Module, AC Voltage	See Note ¹	Power Supplied must be 120 VAC, 60 HZ, 1.0 amps for FC-PSM and 220/240 VAC, 50 Hz, 0.5 amp for FC-PSME (see Note ¹)	Terminals Support 12-18 AWG (see Note ¹)
DC Power (use only if FC-PSM(E) is not installed) Main Board TB3 (power-limited)	Regulated, Power-limited DC power to Main Board, 4.2 amps maximum, 19.1 - 26.4 volts	See Note ¹ Untwisted, unshielded or twisted, shielded	Determined by Voltage range in Standby and Alarm	Terminals support 12-18 AWG (See Note ¹)
Audio Output FCAAM25 Module TB1 (power-limited)	Notification Appliance Circuit	See Note ² Untwisted, unshielded or twisted, shielded	See Note ³	12 - 18 AWG
CMD1 and CMD2 Main Board TB2 and TB5 (nonpower-limited)	Triggers FIRE•COMMAND	See Note ¹ Untwisted, unshielded or twisted, shielded	Depends on Output (trigger) Circuit 9 - 32 VDC, 1.6 mA for polarity reversal relay must be rated at 0.5 amp, 24 VDC	12 - 18 AWG
Main Board TB6 Master Command Bus Reverse Polarity (power-limited)	Output Trigger for Multiple FIRE•COMMAND configurations	Untwisted, unshielded	130 ohms maximum	12 - 18 AWG
Trouble Relay Main Board TB1 (nonpower-limited)	Trouble Output	Maximum Current 2 amps	Depends on Input Circuit	12 - 18 AWG
AC Los Relay FC-PSM(E) Module TB2 (nonpower-limited)	AC Loss Output	Maximum Current 2 amps	Depends on Input Circuit	12 - 18 AWG

1. Refer to NEC Standards.
2. Twisted, shielded wire is recommended for maximum protection against EMI and AFI emissions and susceptibility.
3. Must also meet NFPA 72 Standards for minimum and maximum sound levels.

A

AC Fail Delay 29
AC Loss 37
AC Loss Relay 8, 10, 12, 14
 Contact Rating 12
AC On 7, 29, 35
AC Power 10, 22
AC Power Loss Relay 25, 29
 Contact Rating 25
Addressable Module Connections 49
Alarm 7, 12, 35
Amplifier Fail 7
Amplifier Fault 38
Amplifier Supervision 7, 13
Application 40
Audio Amplifier
 Jumper 27, 28
 Switch S1 27
Audio Amplifier Module 10, 13, 27
Audio Conversion Module 7, 28
Audio Input 7, 11
 Input Current 11
 Input Impedance 11
 Input Voltage 11
Audio Power 6
 25 watts 6, 11
 50 watts 6
Auxiliary Audio Input 7
Auxiliary Power 7, 23

B

Background Music 12, 15, 17, 22, 37
Backup Amplifier 13, 27, 41
Backup Audio 10
Battery 10, 13, 22
 Alarm 46
 Charger Capacity 10
 Charging Circuit 10
 Standby 45
Battery Box 13, 21
Battery Calculations 45
Battery Charger 12, 13, 14, 22, 29, 45
Battery Trouble 7, 29, 35, 37
BB-17F 13
Bypass Switch 18

C

Cabinet 13
Cabinet Dimensions 20
Charger 10
Chime Tone 7, 15
Circuit Trouble 35
Circuits 12
CMD1 12, 17, 23, 24, 37
 see also Command Input Circuit 10
CMD2 12, 17, 23, 24, 37
 see also Command Input Circuit 10
Command Input Circuit 10, 17, 23
 Contact Closure Current 10
 End-of-Line Resistor 10
 Operating Voltage 10
 Reverse Polarity Current 10
Contact Rating
 AC Loss Relay 10
Contact-closure 10
Controls 11
 see also Switches 11
Custom Message 7
 30 second (two) 7

60 second (one) 7

D

DIP Switches
 S5 16
Dress Panel 7, 13
Dual-message 7

E

Earth Ground 22
End-of-Line Resistor 10, 11, 24

F

FACP 7, 10
FC-AAM25 10, 13, 27
FC-LPS 11, 14, 31
 see also Local Playback Speaker 12
FCPS-24F(E) 7, 10, 22, 48
FC-PSM(E) 7, 8, 10, 12, 14, 22
FC-XRM70 13, 14, 27, 28
 see also Audio Conversion Module 13
Fire Alarm 36
Fire Alarm Control Panel
 see also FACP 6
Fire Alarm Restoral 36
FIRE•COMMAND•25/50 6
 see also Voice Evacuation Control Panel 6
Form-C 8, 11, 12, 25
 see Relay

G

Ground Fault 7, 29, 35, 37

H

Hi-Lo Tone 7, 15

I

Indicators 11
Input Circuits 12, 23

J

Jumper 22
 Audio Amplifier 10

K

Knockout Locations 20

L

LED 7, 12, 13, 27, 29, 35
Lightning Protection 22
Local Playback Speaker 7, 8, 12, 14, 31

M

Main Circuit Board 13
Manual Evacuate 7, 11, 32, 36
Master CMD Out 11
 Operating Voltage 11
 Short Circuit Current 11
Master Command 37
Master Command Output 24
 End-of-Line Resistor 24
Message Generator Trouble 7, 12, 35, 37
Message Override 7, 11, 32, 37
Message Playback 11
Message Recording 16
Message Repeat 16
Message Repeater 7
Messages 47

Microphone 32
Microphone Trouble 7, 12, 35, 37
Mounting 19
MR-101C 11, 24
MR-201C 11, 24

N

NAC 6, 38, 39
 End-of-Line Resistor 25
 see also Notification Appliance Circuit 6
 Style Y 6, 12
 Style Z 6, 12
Nonpower-limited 26
Notification Appliance Circuit 6, 12, 23, 25

O

Operation 35
Option Modules 13, 27
Output Circuit 12, 24

P

Piezo 7
Playback 34
Power 7, 10, 11, 22, 38, 39
 see also FC-PSM(E) 7
Power On 7, 12, 35
Power Supply 13, 14, 22, 29, 45
 see also FC-PSM(E) 7
Power-limited 26
Power-limited Circuit 10, 11
Primary Message 7
Primary Power 22
Product Description 6
Product Features 6
Programming 10, 12, 15, 23
 DIP Switches 15

R

RCA Jack 11, 12, 32
 see also Audio Input 11
Record 7, 32, 35
 30 Second Message (two) 32, 33
 60 Second Message (one) 32, 33
 Bypass Switch 18
 Enable 18
 From Microphone 17
 From RCA Jack 17
Record (REC) 12
Record Bypass 32
Recording Instructions 32
Relay 7, 11, 12

S

Secondary Message 7
Secondary Power 22
Semi-flush Mount 19
Slow-Whoop Tone 7, 15
Sunder 7
 see also Piezo 7
Speaker Circuit 6, 11, 25
 End-of-Line Resistor 11
 Operating Voltage 11
 see also NAC 6
 Style Y 11
 Style Z 11
Speaker/Message Selection 16
Specific Application Power 11, 12, 23
Steady Tone 7, 15

Supervision 6, 11, 13, 35
Surface Mount 19
Switch 7
 S1 Audio Amplifier 10
Switches 11, 32
 S1 15
 S5 15
System Trouble 7, 12, 35

T

Temporal Pattern 15
Tone 7
Tone After Message 16
Tone Before Message 15
Tone Generator 7
Tone Generator Fault 37
Tone Generator Trouble 7, 12, 35
Transformer 8
Transformer Installation 30
Transient Protection 22
Trouble 38
Trouble Relay 8, 11, 25
 Contact Rating 11, 12, 25
Trouble Silence 11, 32

U

UL Power-limited Wiring 26

V

VECP 6, 12, 22
 see also Voice Evacuation Control Panel 6
VECP Backbox 21
Voice Evacuation Control Panel 6

W

Wiring Fault 7
Wiring Requirements 50

Notes

Notes

Notes

Limited Warranty

Fire-Lite® warrants its products to be free from defects in materials and workmanship for eighteen (18) months from the date of manufacture, under normal use and service. Products are date stamped at time of manufacture. The sole and exclusive obligation of **Fire-Lite®** is to repair or replace, at its option, free of charge for parts and labor, any part which is defective in materials or workmanship under normal use and service. For products not under **Fire-Lite®** manufacturing date-stamp control, the warranty is eighteen (18) months from date of original purchase by **Fire-Lite®**'s distributor unless the installation instructions or catalog sets forth a shorter period, in which case the shorter period shall apply. This warranty is void if the product is altered, repaired or serviced by anyone other than **Fire-Lite®** or its authorized distributors or if there is a failure to maintain the products and systems in which they operate in a proper and workable manner. In case of defect, secure a Return Material Authorization form from our customer service department. Return product, transportation prepaid, to **Fire-Lite®**, One Fire-Lite Place, Northford, Connecticut 06472-1653.

This writing constitutes the only warranty made by **Fire-Lite®** with respect to its products. **Fire-Lite®** does not represent that its products will prevent any loss by fire or otherwise, or that its products will in all cases provide the protection for which they are installed or intended. Buyer acknowledges that **Fire-Lite®** is not an insurer and assumes no risk for loss or damages or the cost of any inconvenience, transportation, damage, misuse, abuse, accident or similar incident.

Fire-Lite® GIVES NO WARRANTY, EXPRESSED OR IMPLIED, OF MERCHANTABILITY, FITNESS FOR ANY PARTICULAR PURPOSE, OR OTHERWISE WHICH EXTEND BEYOND THE DESCRIPTION ON THE FACE HEREOF. UNDER NO CIRCUMSTANCES SHALL **Fire-Lite®** BE LIABLE FOR ANY LOSS OF OR DAMAGE TO PROPERTY, DIRECT, INCIDENTAL OR CONSEQUENTIAL, ARISING OUT OF THE USE OF, OR INABILITY TO USE **Fire-Lite®** PRODUCTS. FURTHERMORE, **Fire-Lite®** SHALL NOT BE LIABLE FOR ANY PERSONAL INJURY OR DEATH WHICH MAY ARISE IN THE COURSE OF, OR AS A RESULT OF, PERSONAL, COMMERCIAL OR INDUSTRIAL USE OF ITS PRODUCTS.

This warranty replaces all previous warranties and is the only warranty made by **Fire-Lite®**. No increase or alteration, written or verbal, of the obligation of this warranty is authorized.

"**Fire-Lite**" is a registered trademark.



Fire-Lite® ALARMS
INCORPORATED

One Fire-Lite Place, Northford, CT 06472
Phone: (203) 484-7161
FAX: (203) 484-7118